

3700339COM 5 Drawer Dresser

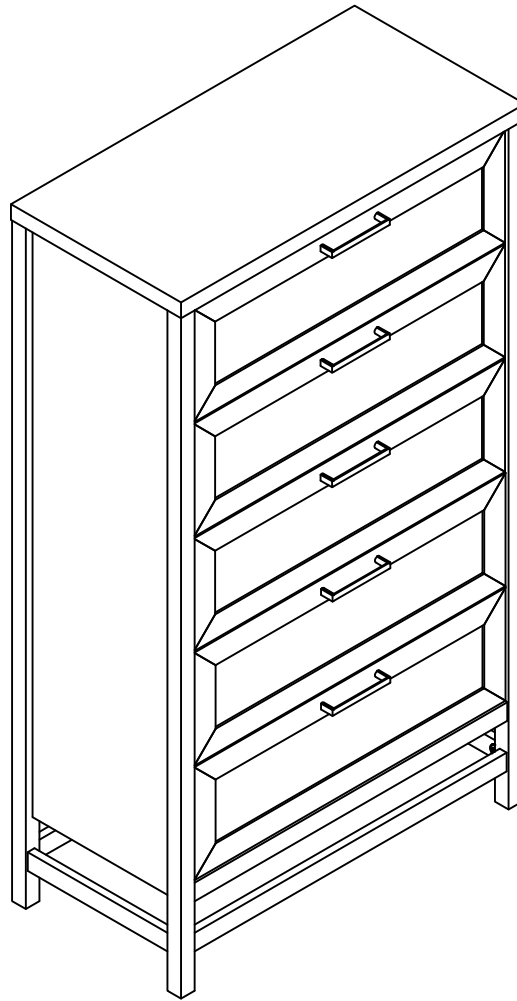

Date of Purchase ___ / ___ / ___
Lot Number:

B343700339COM2



Do Not Return This Product!
Contact our customer service team for help first.
Call: 1-800-489-3351 (toll free)
Monday-Friday 9am - 5pm CST
Visit: www.ameriwoodhome.com

THIS INSTRUCTION BOOKLET CONTAINS **IMPORTANT** SAFETY INFORMATION. PLEASE READ AND KEEP FOR FUTURE REFERENCE.

Secure Your Furniture

Keep your home and family safe with the wall anchor kit that is included with the product.

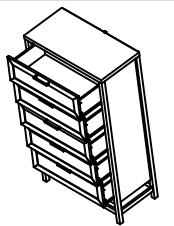

Serious or fatal crushing injuries can occur from tipping furniture.

WARNING: Manufacturer assumes no liability for improper installation or excessive loads placed on screws or bracket. This wall anchor is not a substitute for proper adult supervision.

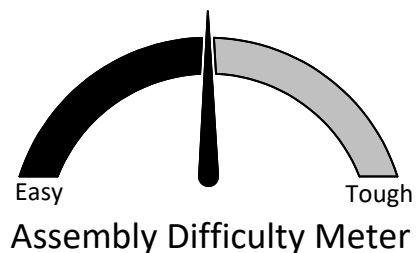

Follow Ameriwood Home



Contact Us!

Do NOT return this product!

Contact our friendly customer service team first for help.



Visit ameriwoodhome.com to view the limited warranty valid in the U.S. and Canada.

Assembly Tips



Helpful Hints

PEOPLE NEEDED FOR ASSEMBLY: 1-2

- Open your item in the area you plan to keep it to avoid excessive heavy lifting.
- Identify, sort and count the parts before attempting assembly.
- Compression dowels are lightly tapped in with a hammer.
- Slides are labeled with a **R** (right) and **L** (left) for proper placement.
- Make sure to always face the point on the top of the Cam Lock towards the outer edge.
- Use all the nails provided for the back panel and spread them out equally.
- Back panel must be used to make sure your unit is sturdy.
- Do NOT use harsh chemicals or abrasive cleaners on this item.
- Never push, pull, or drag your furniture.

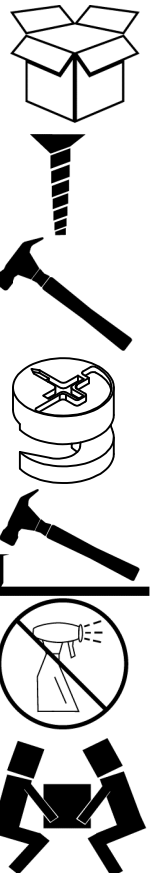

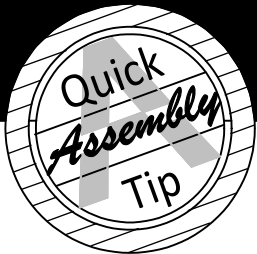

Before You Start



- ✓ Read through each step carefully and follow the proper order
- ✓ Separate and count all your parts and hardware
Parts are labeled on the surface or edge of the part
- ✓ Give yourself enough room for the assembly process
- ✓ Have the following tools: Flat Head Screwdriver, #2 Phillips Head Screwdriver and Hammer
- ✓ Caution: If using a power drill or power screwdriver for screwing, please be aware to slow down and stop when screw is tight. Failure to do so may result in stripping the screw.

Cam Lock Fastening System

This Cam Lock Fastening System will be used throughout the assembly process.

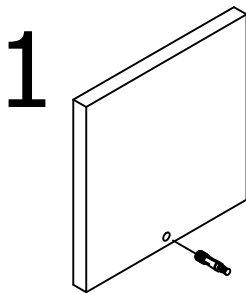

1 Press CAM BOLT into hole.

2

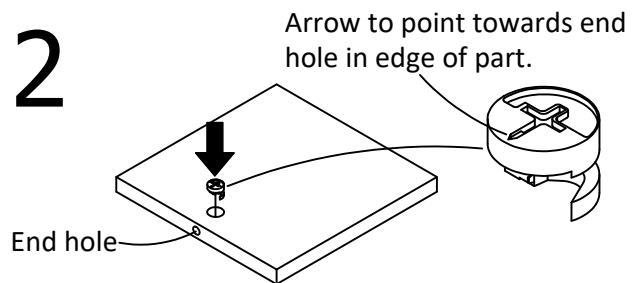

Press CAM LOCK into hole.

3

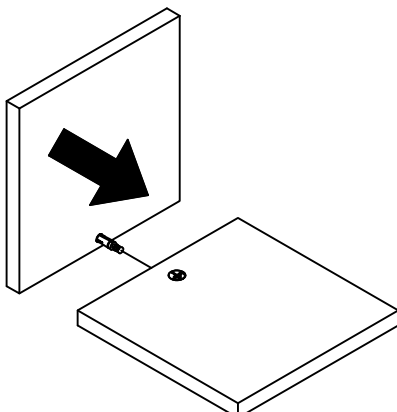

Press parts together so CAM BOLT inserts into edge hole.

4

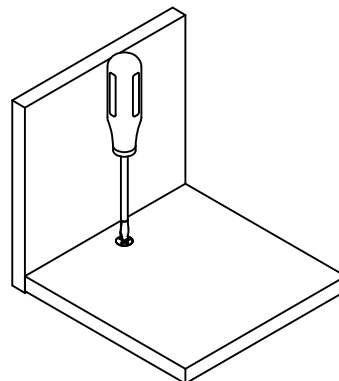

Using a screwdriver, turn the CAM LOCK clockwise to lock the CAM LOCK and CAM BOLT into their holes and fastening parts together.

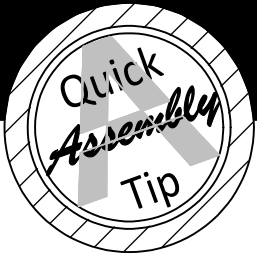

Before You Start

Please Note:

You may need to lightly tap the wood dowels into the holes during your assembly process.

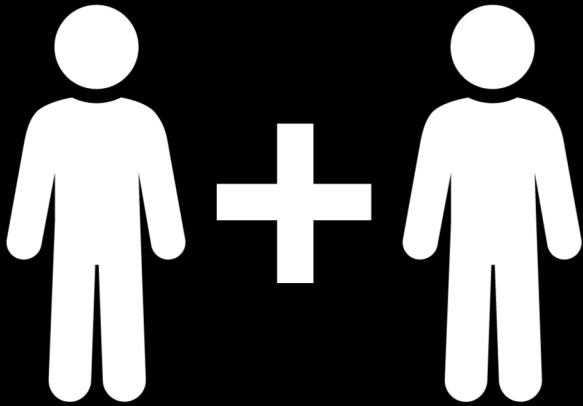
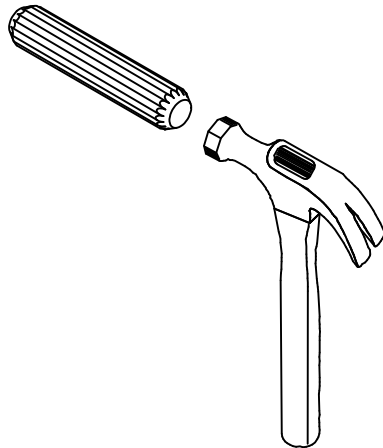

2 PEOPLE NEEDED FOR ASSEMBLY

**2 PERSONAS NECESITADAS
PARA LA ASAMBLEA**

**2 PERSONNES NÉCESSAIRES
POUR L'ASSEMBLAGE**

CAUTION: Failure to use 2 people for assembly could result in unit damage or personal injury.

PRECAUCIÓN: Si no se utilizan 2 personas para el ensamblaje, se pueden producir daños en la unidad o lesiones personales.

ATTENTION: Échec d'utiliser 2 personnes pour l'assemblage peut causer du dommage au meuble ou causer des blessures.

Board Identification

Not actual size

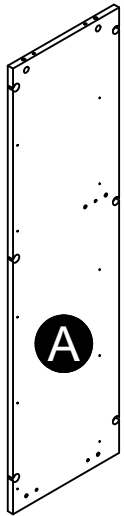

Left Panel
33700339010

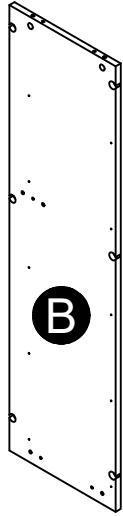

Right Panel
33700339020

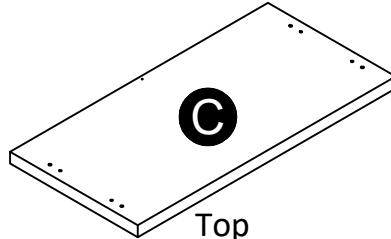

Top
33700339030

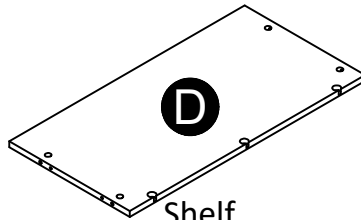

Shelf
33700339040

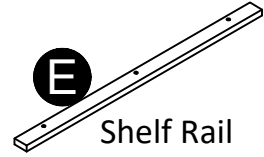

Shelf Rail
33700339050

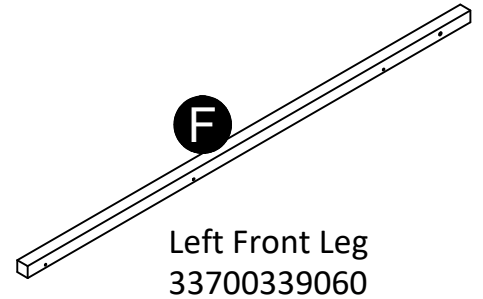

Left Front Leg
33700339060

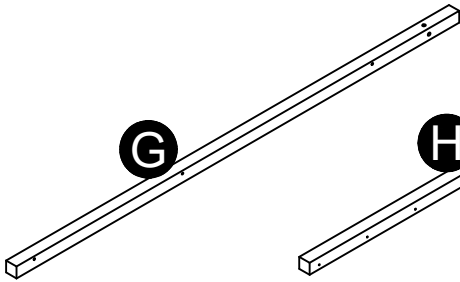

Right Front Leg
33700339070

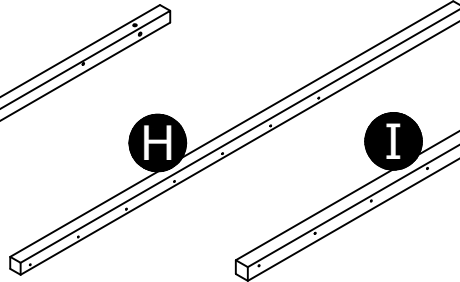

Left Rear Leg
33700339080

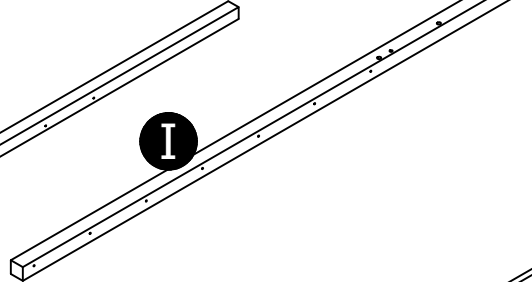

Right Rear Leg
33700339090

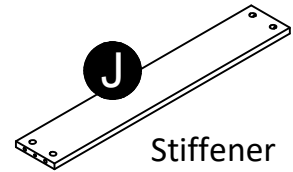

Stiffener
33700000100

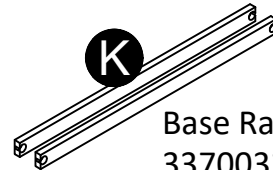

Base Rail (x2)
33700339110

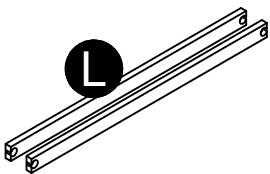

Base Side Rail (x2)
33700339120

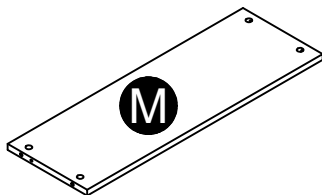

Lower Back
33700000130

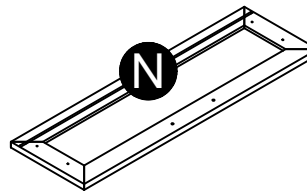

Drawer Front (x5)
33700339140

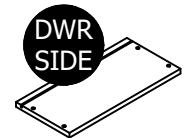

Drawer Side (x10)
39991167346200C

Board Identification

Not actual size

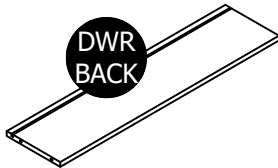

Drawer Back (x5)
39991167068290B

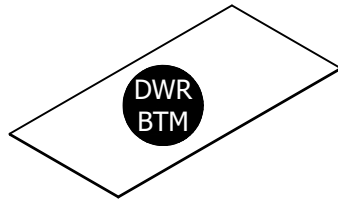

Drawer Bottom (x5)
39991339069310D

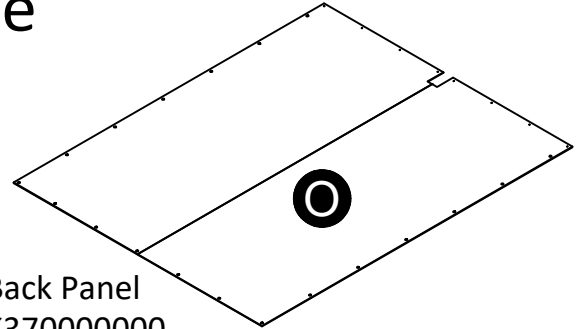

Back Panel
K370000000

This piece is paperboard construction. It is not made from wood, but is required for the assembly of your unit.

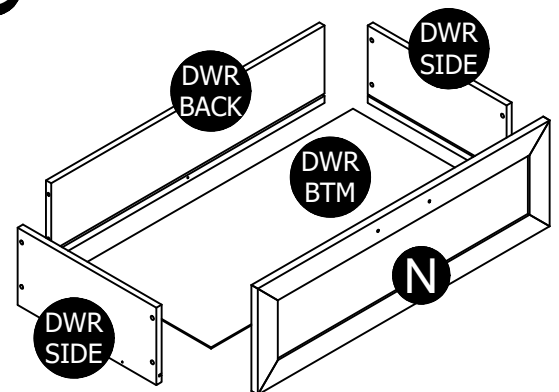
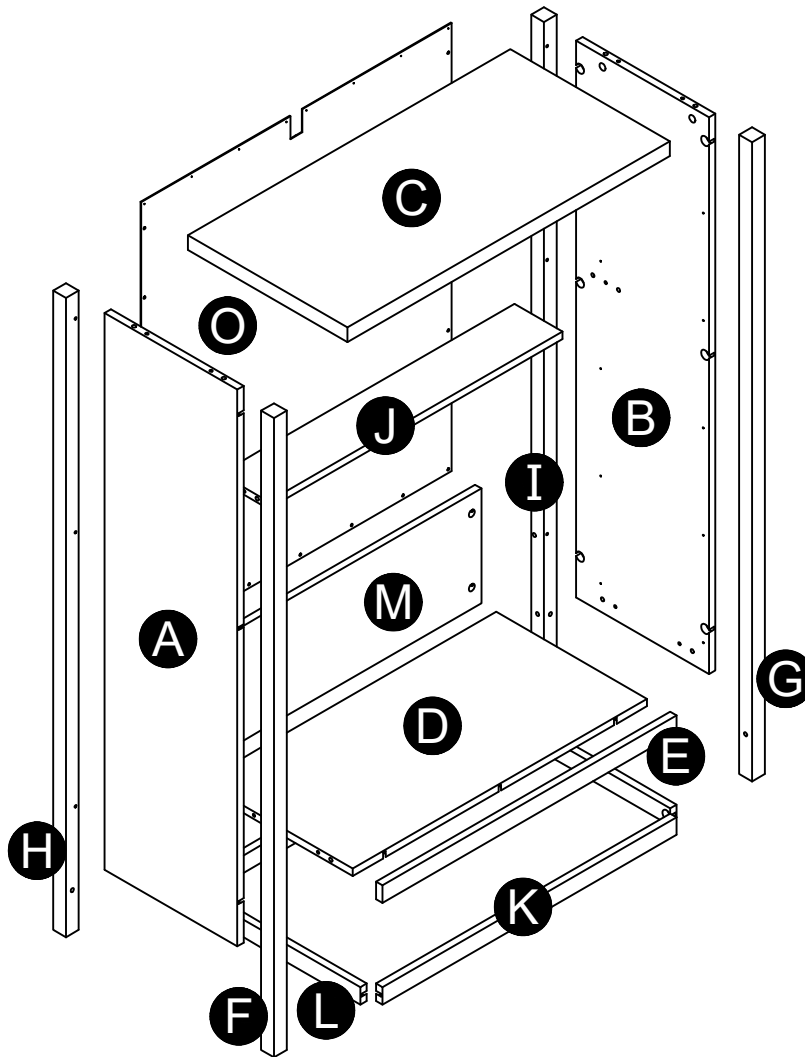

Part List

Actual Size

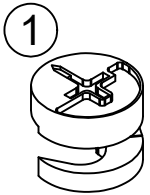

(x16)
#A22700
cam lock

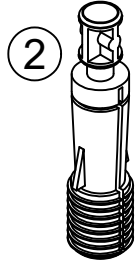

(x16)
#A22710
cam bolt



(x12)
#A21670
wood dowel

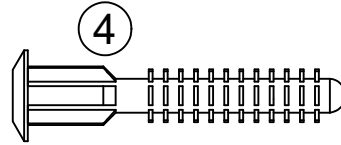

(x20)
#A21970
drive fastener



(x12)
#A22910
connector bolt

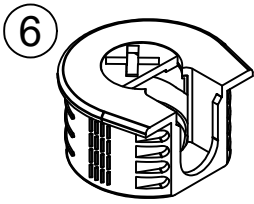

(x12)
#A22900
connector



(x40)
#A11080
7/16" flat head



(x69)
#A12120
7/16" pan head

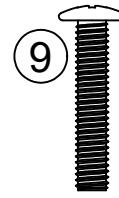

(x10)
#A17400
7/8" bolt

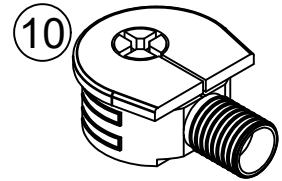

(x11)
#A22760
quickloc

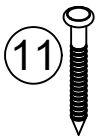

(x8)
#A21110
nail

Not Actual Size



(x1)
#A84050
safety bracket kit

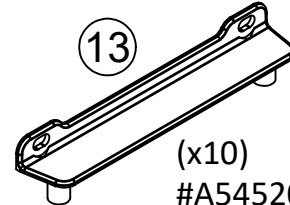
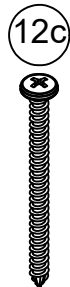
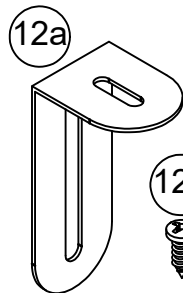

(x10)
#A54520
drawer bracket

Part List

Not Actual Size

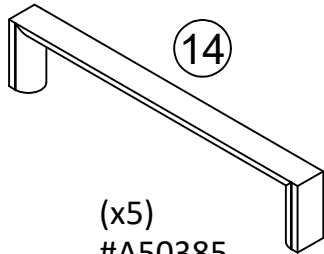

14

(x5)
#A50385
handle



15a

left cabinet member



15b

right cabinet member

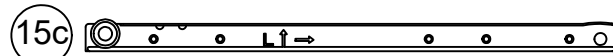

15c

left drawer member

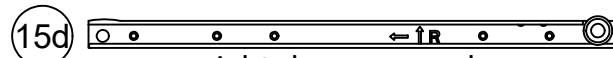

15d

right drawer member

(x5)
15 #A56770
drawer slide kit

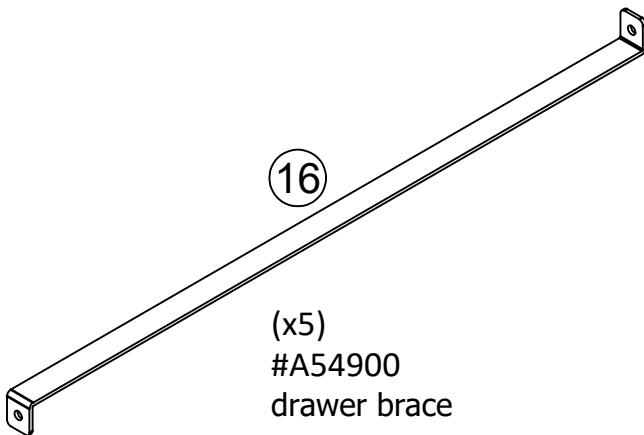

16

(x5)
#A54900
drawer brace

STEP 1

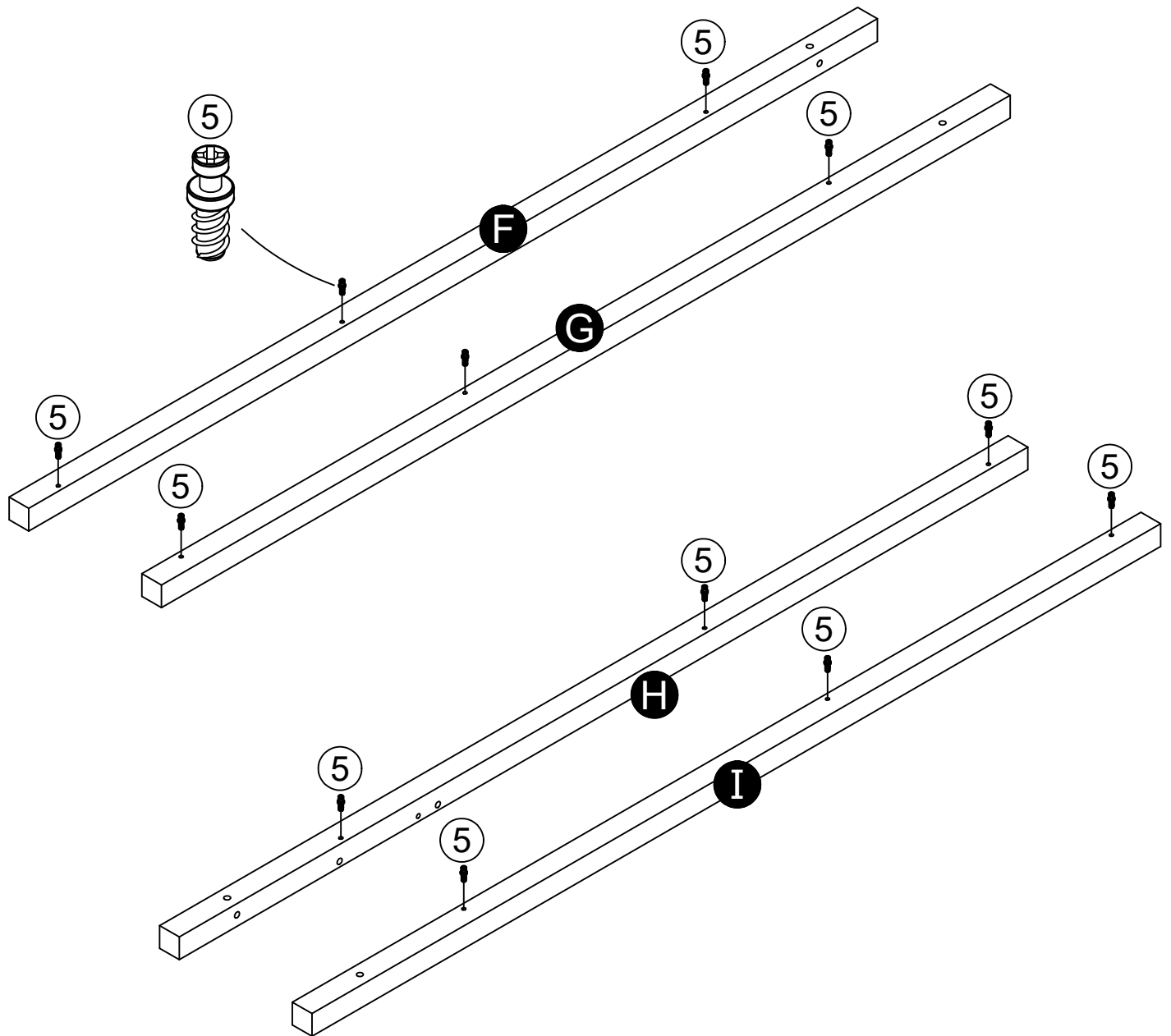
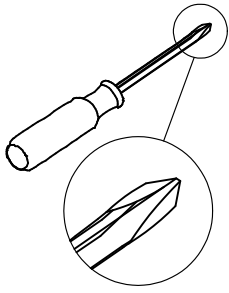

STEP 2

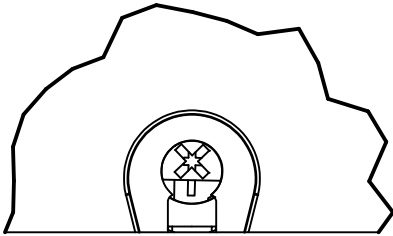
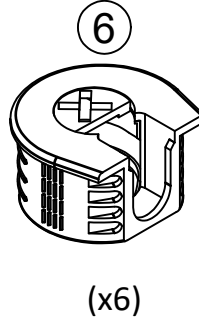
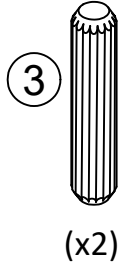
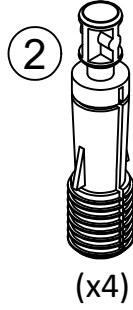
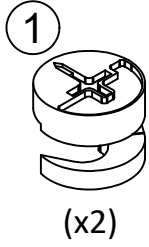

You will need to tap the connector (6) with a hammer to fully insert. Be sure the connector is positioned as shown before tapping into hole.

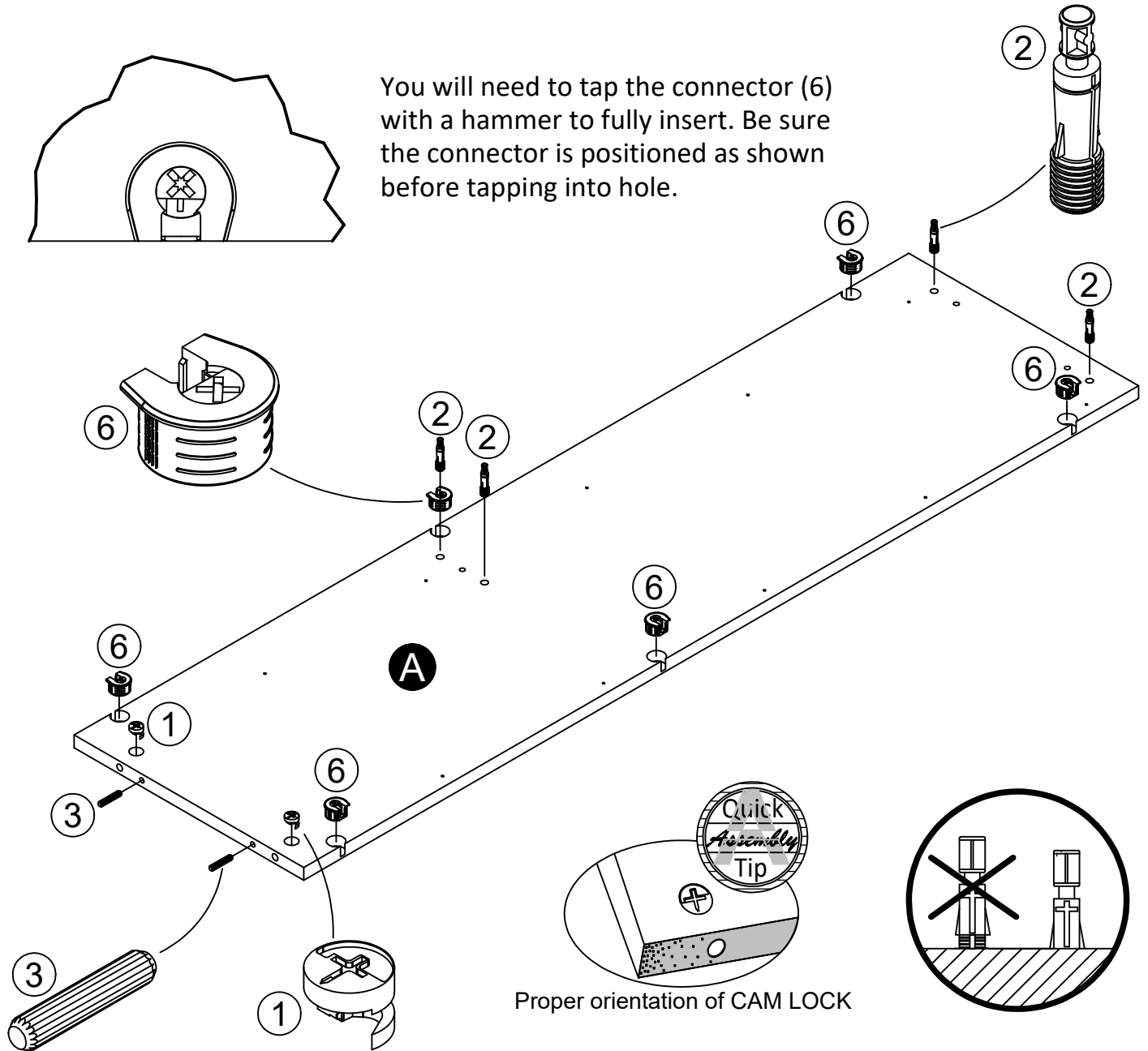

STEP 3

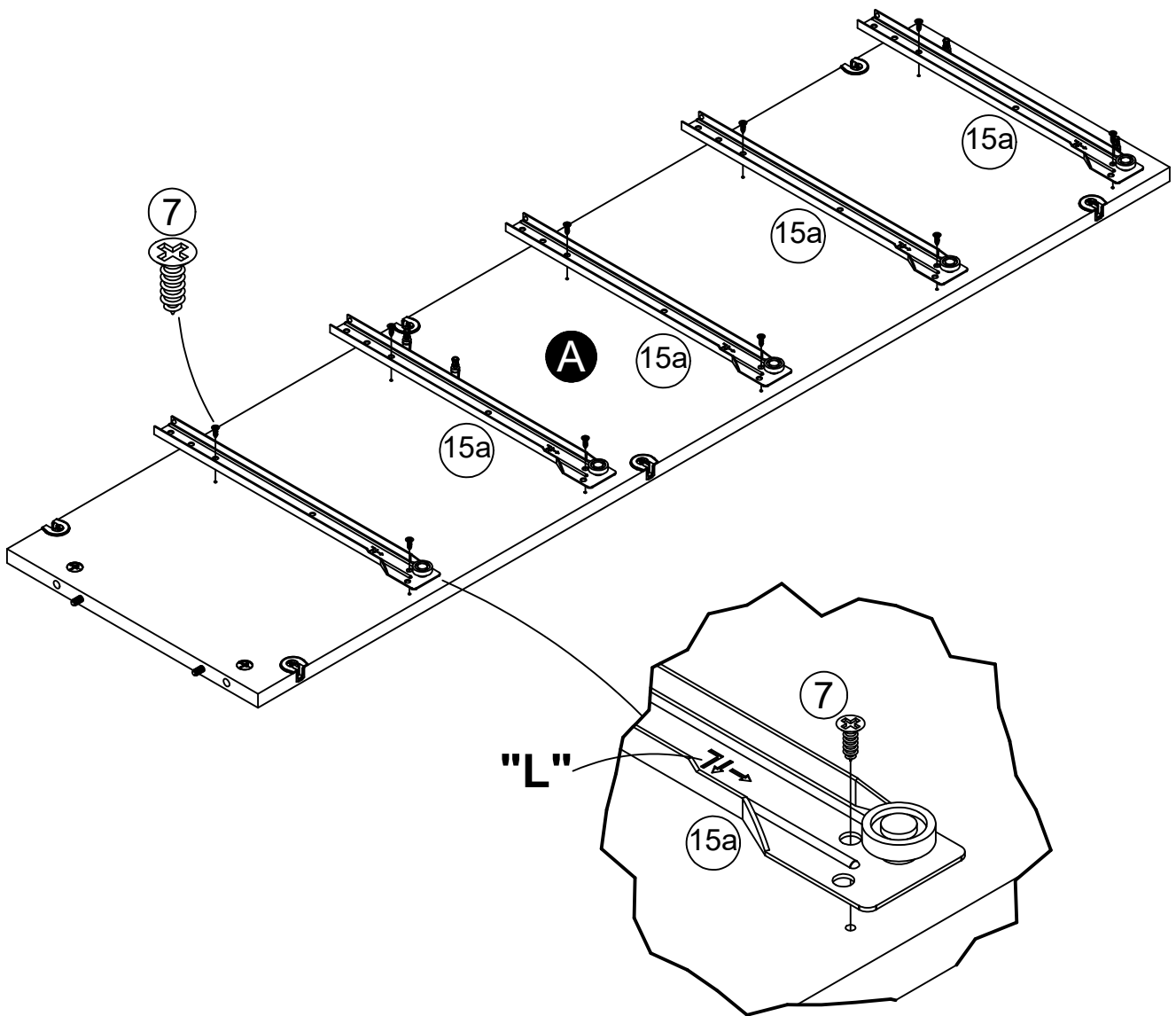
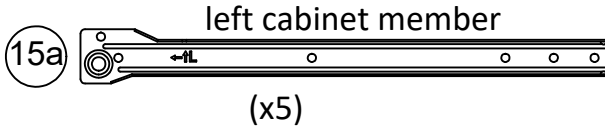
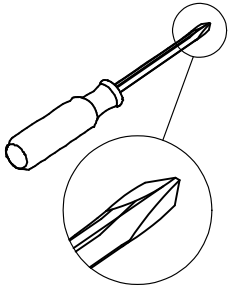

STEP 4

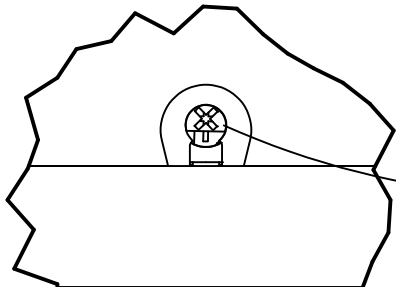
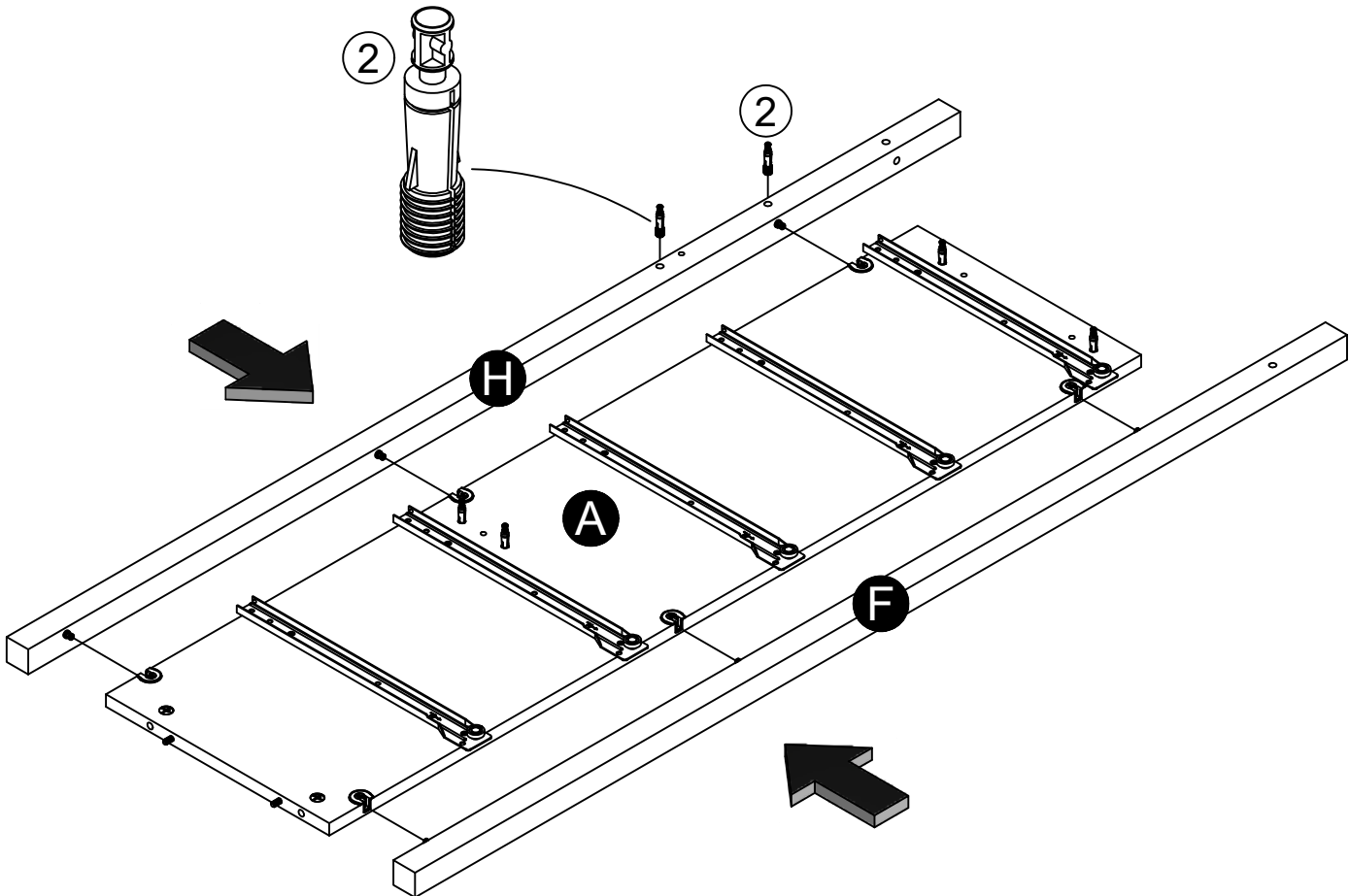
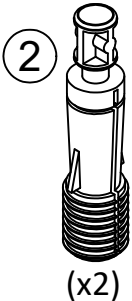

Turn screw clockwise to lock parts in place.

STEP 5

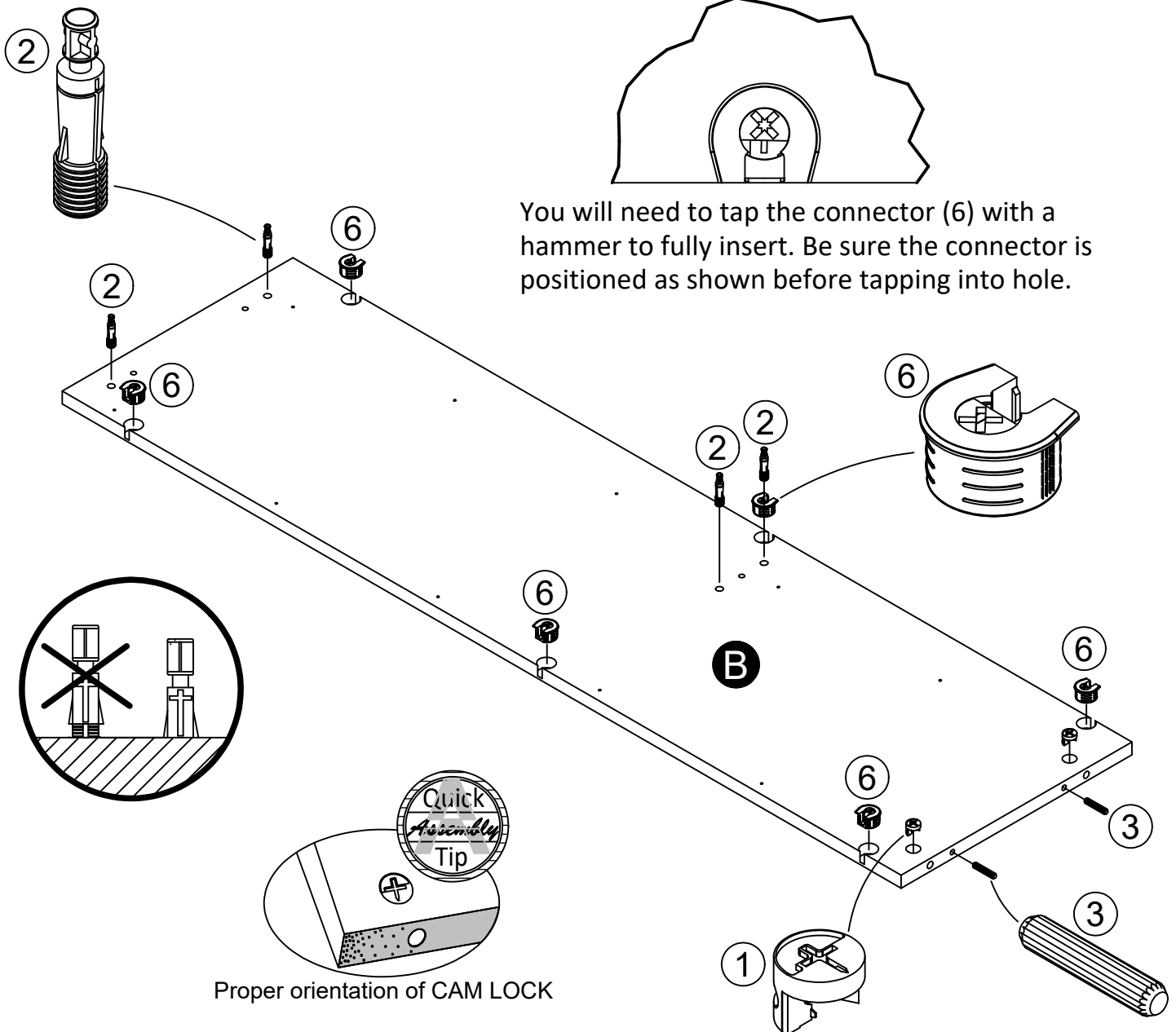
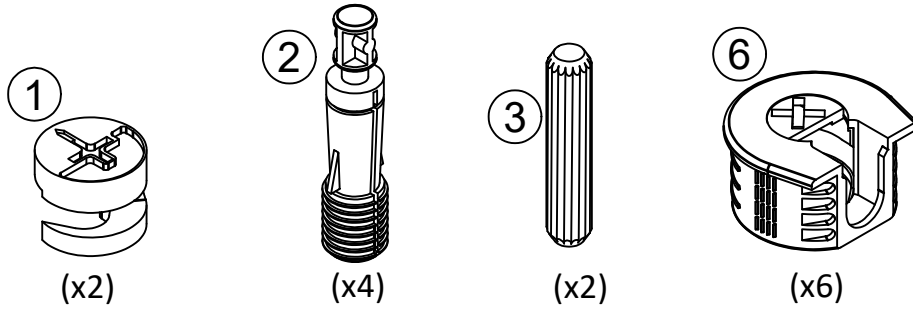

STEP 6

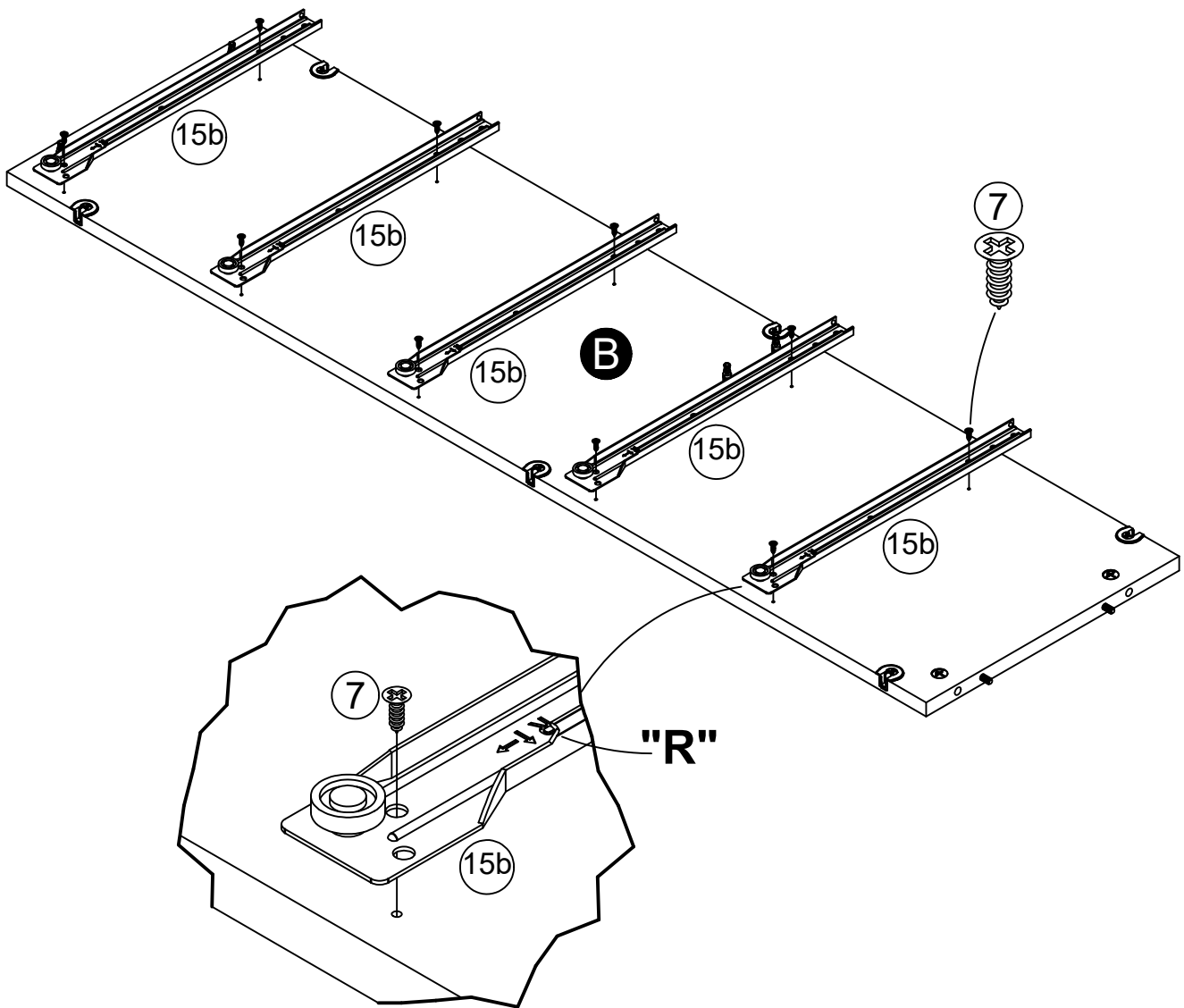
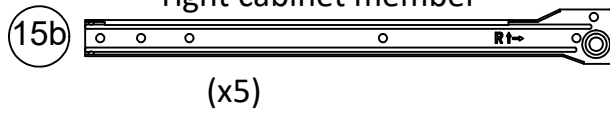
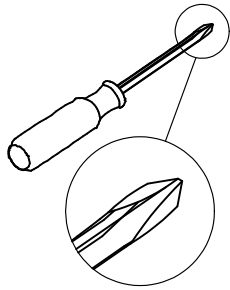

STEP 7

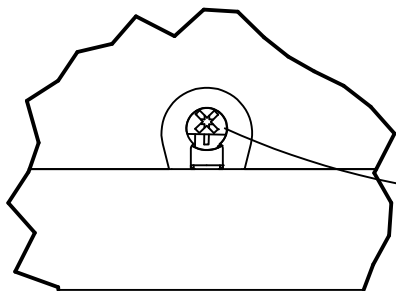
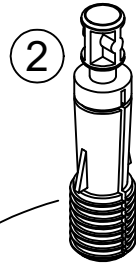
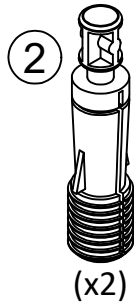
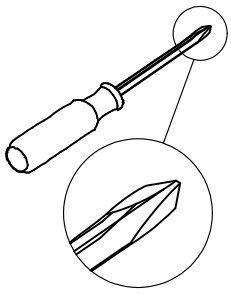
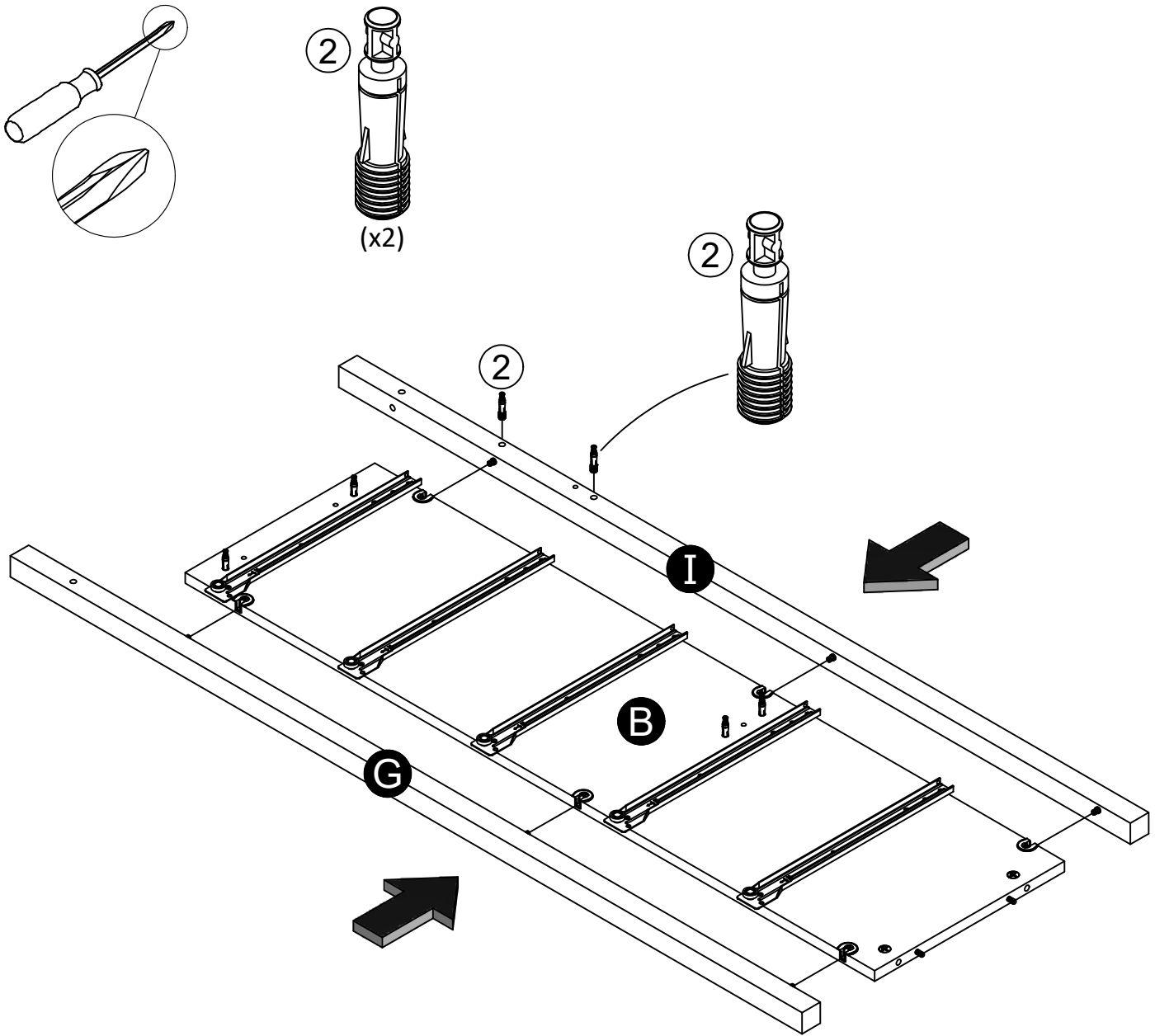

Turn screw clockwise to lock parts in place.

STEP 8

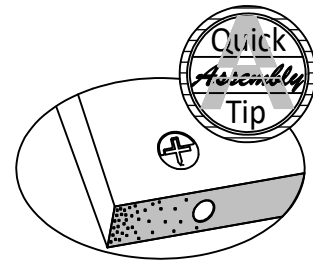
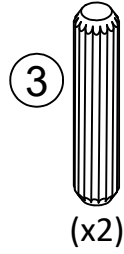
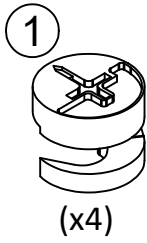

Proper orientation of CAM LOCK

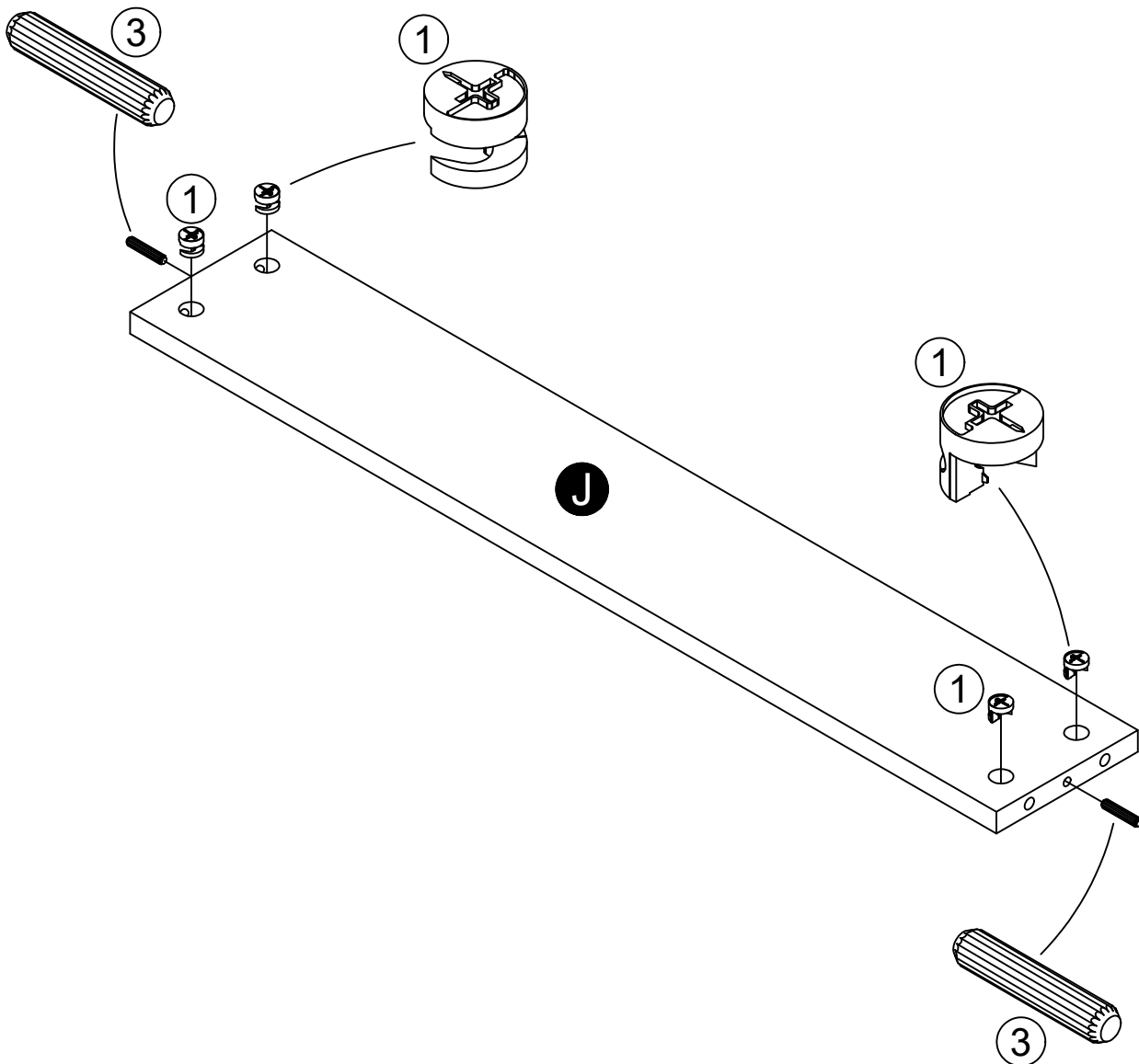

STEP 9

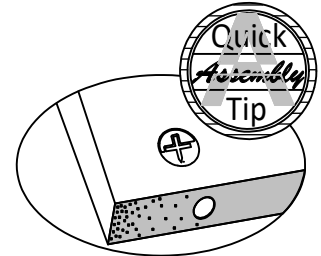
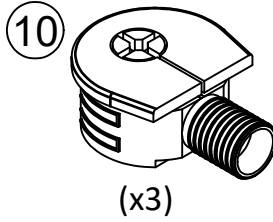
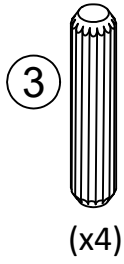
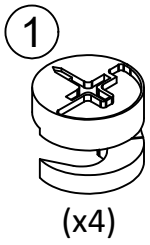

Proper orientation of CAM LOCK

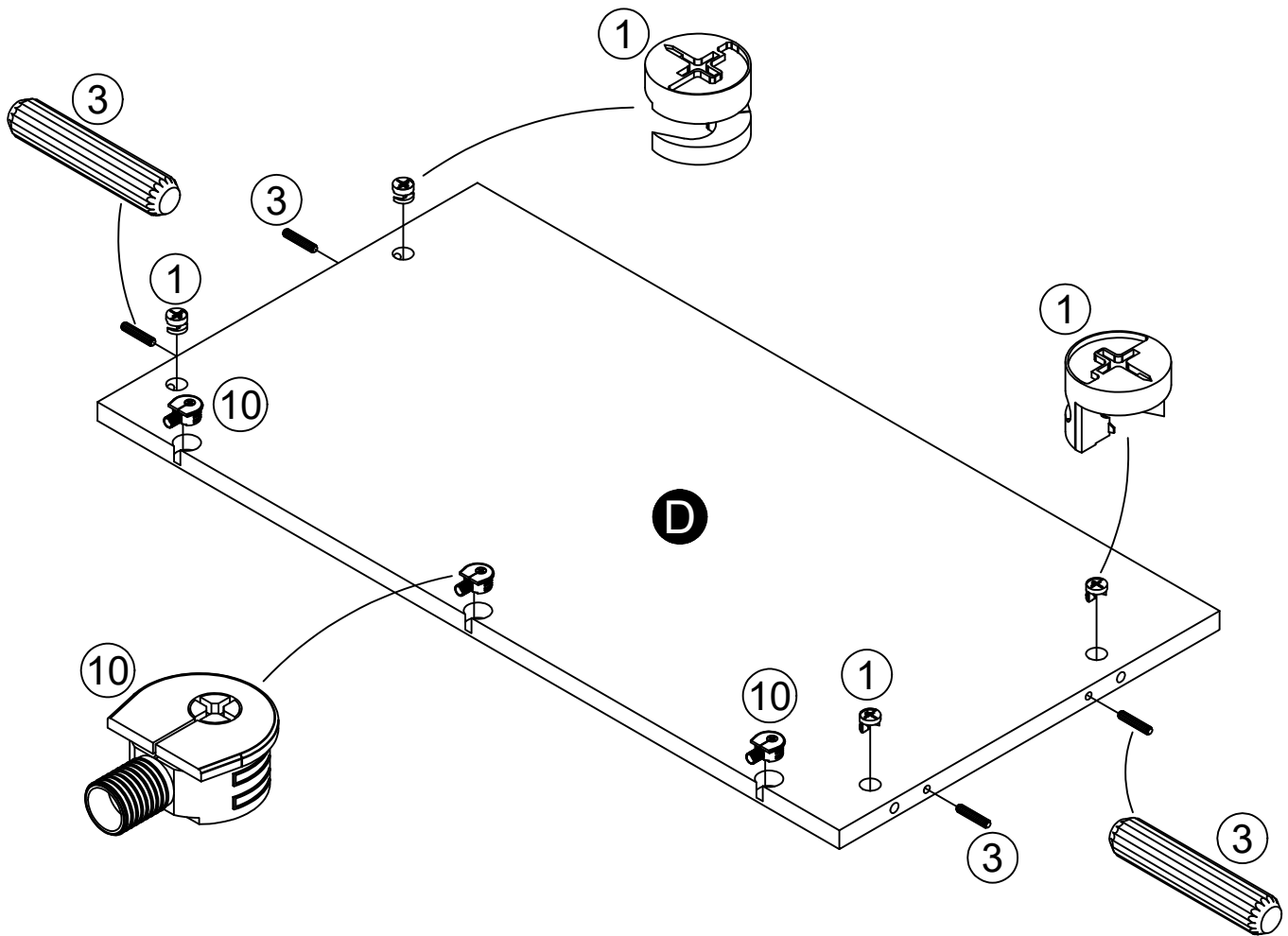

STEP 10

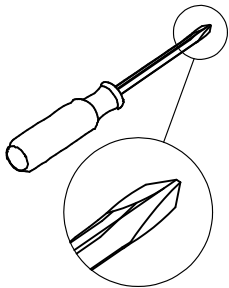

Align the holes in the Shelf Rail (E) with the quicklocs (10) and press down. Lock parts together by turning screw in quickloc clockwise.

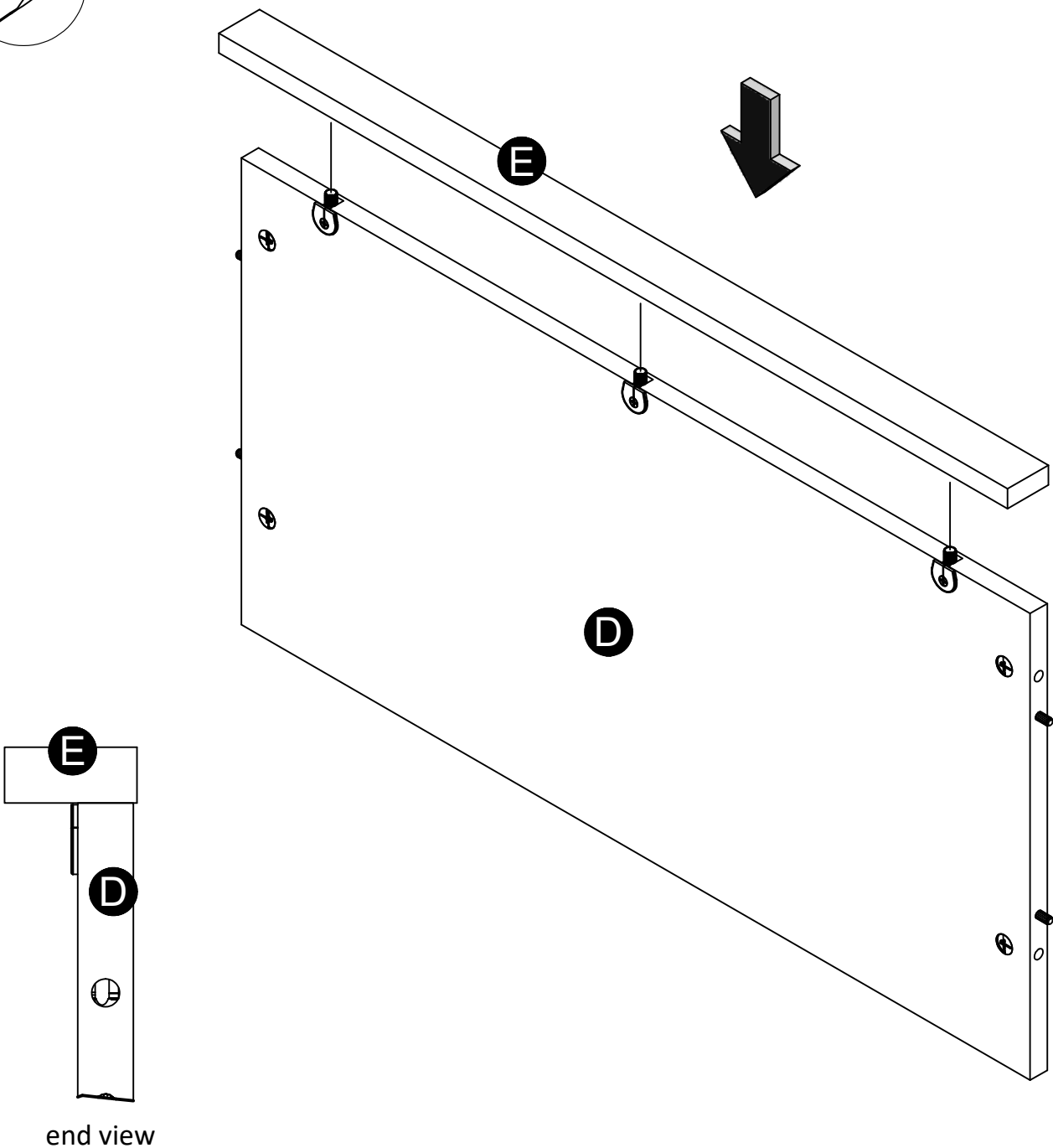

STEP 11

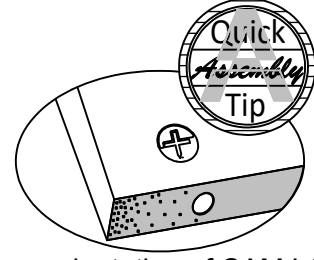
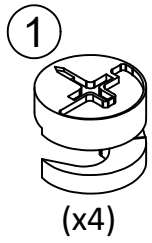

Proper orientation of CAM LOCK

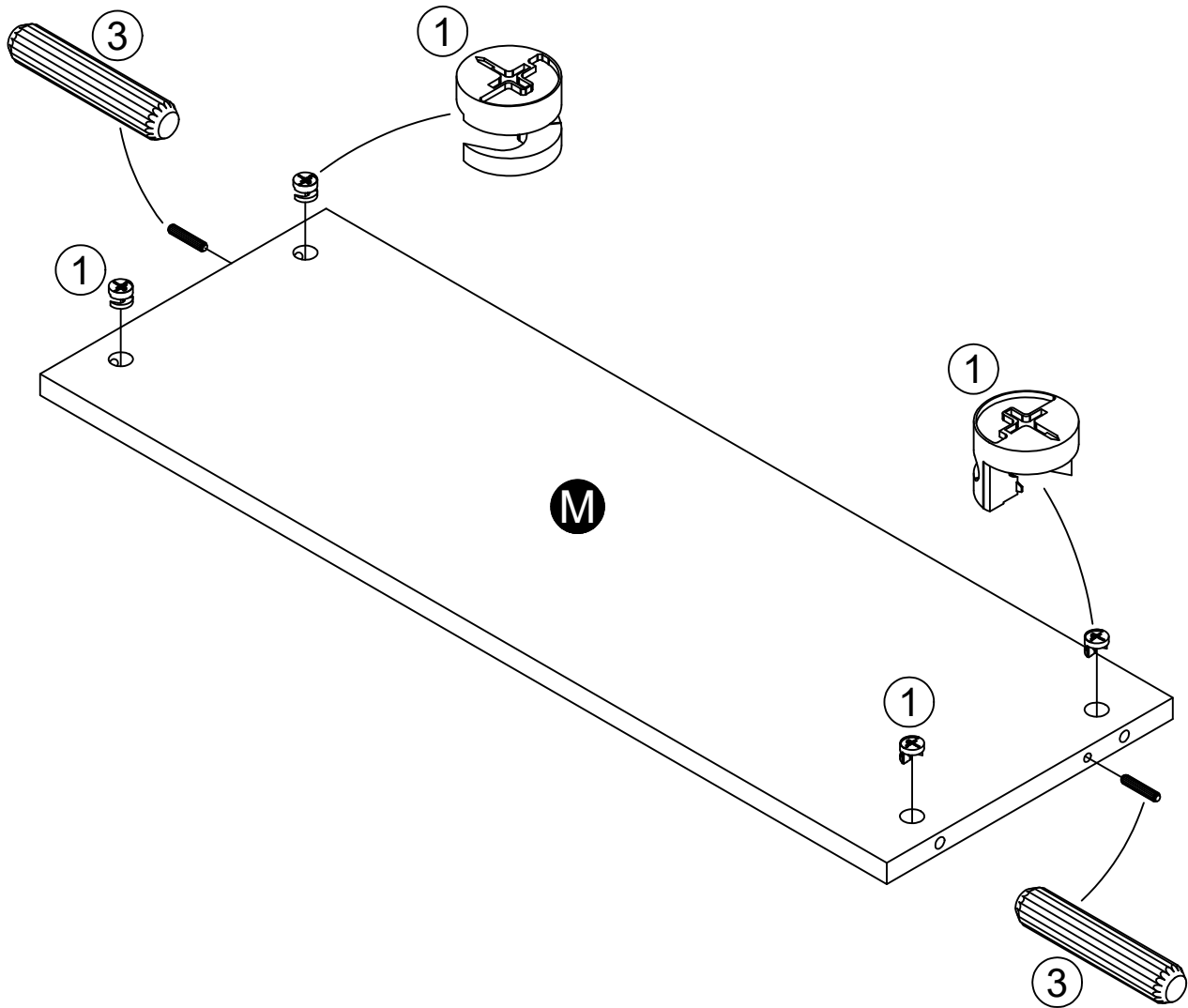

STEP 12

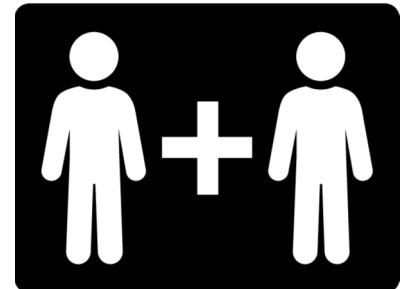
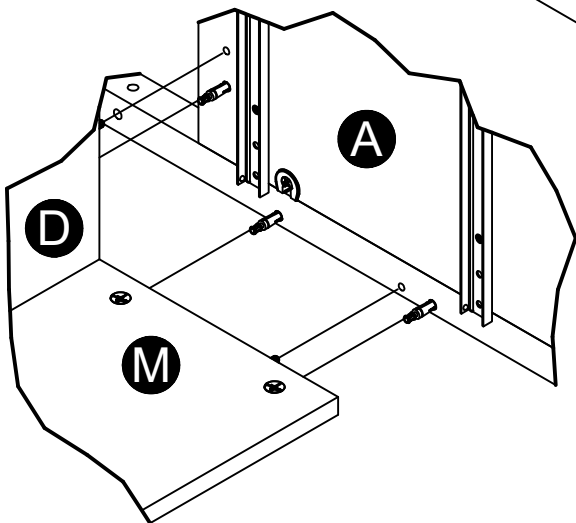
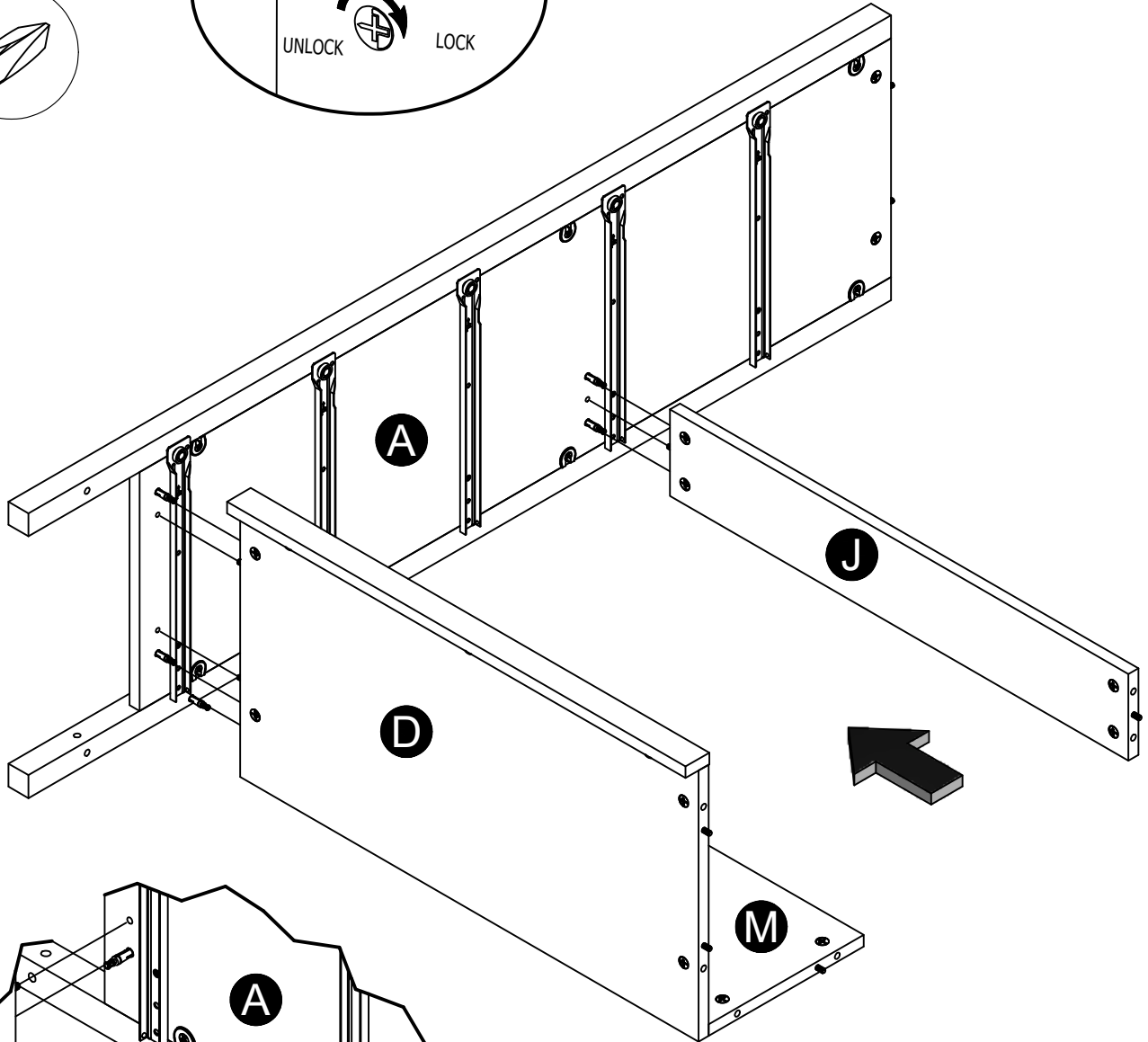
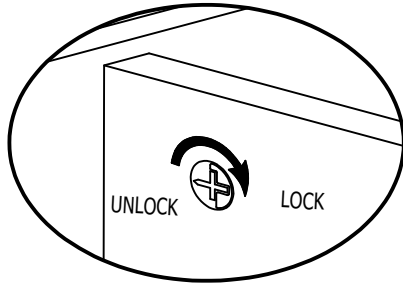
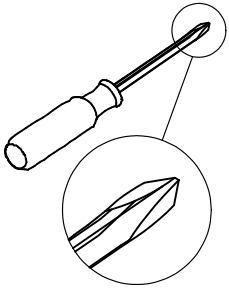

STEP 13

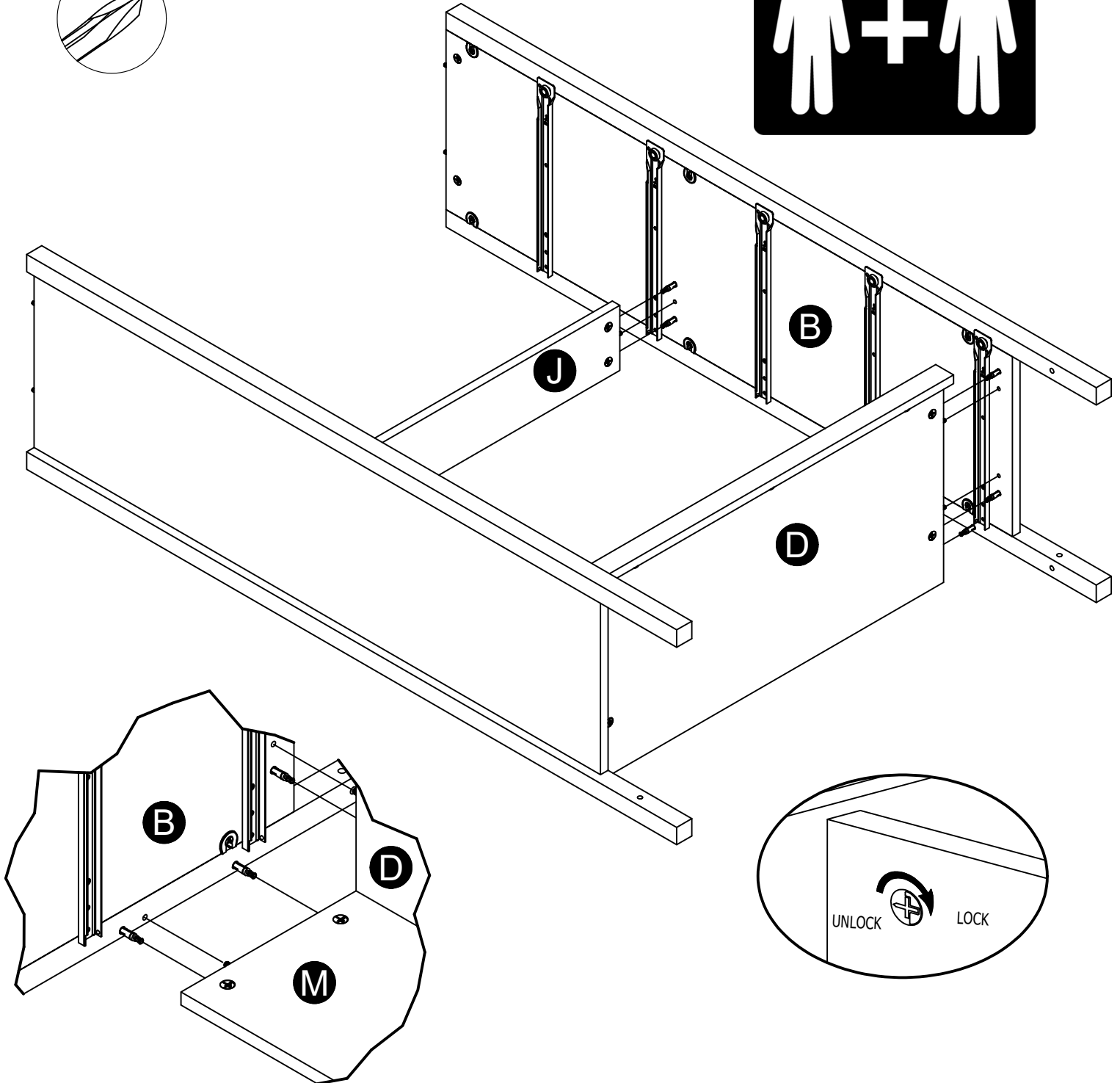
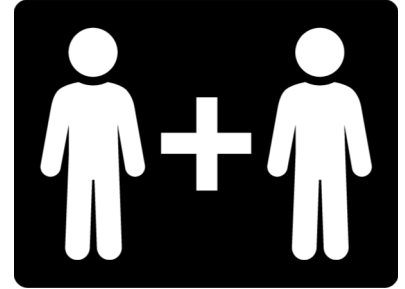
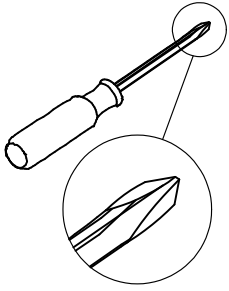

STEP 14

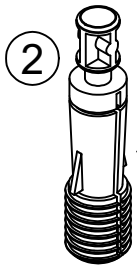
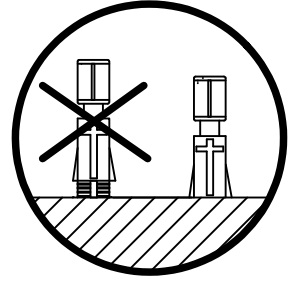
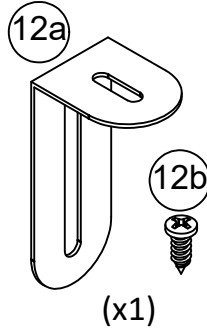
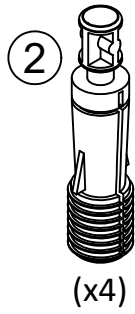
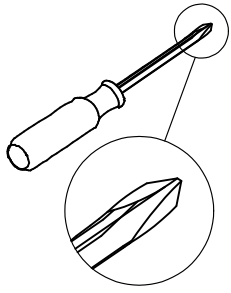

Do not fully tighten screw.

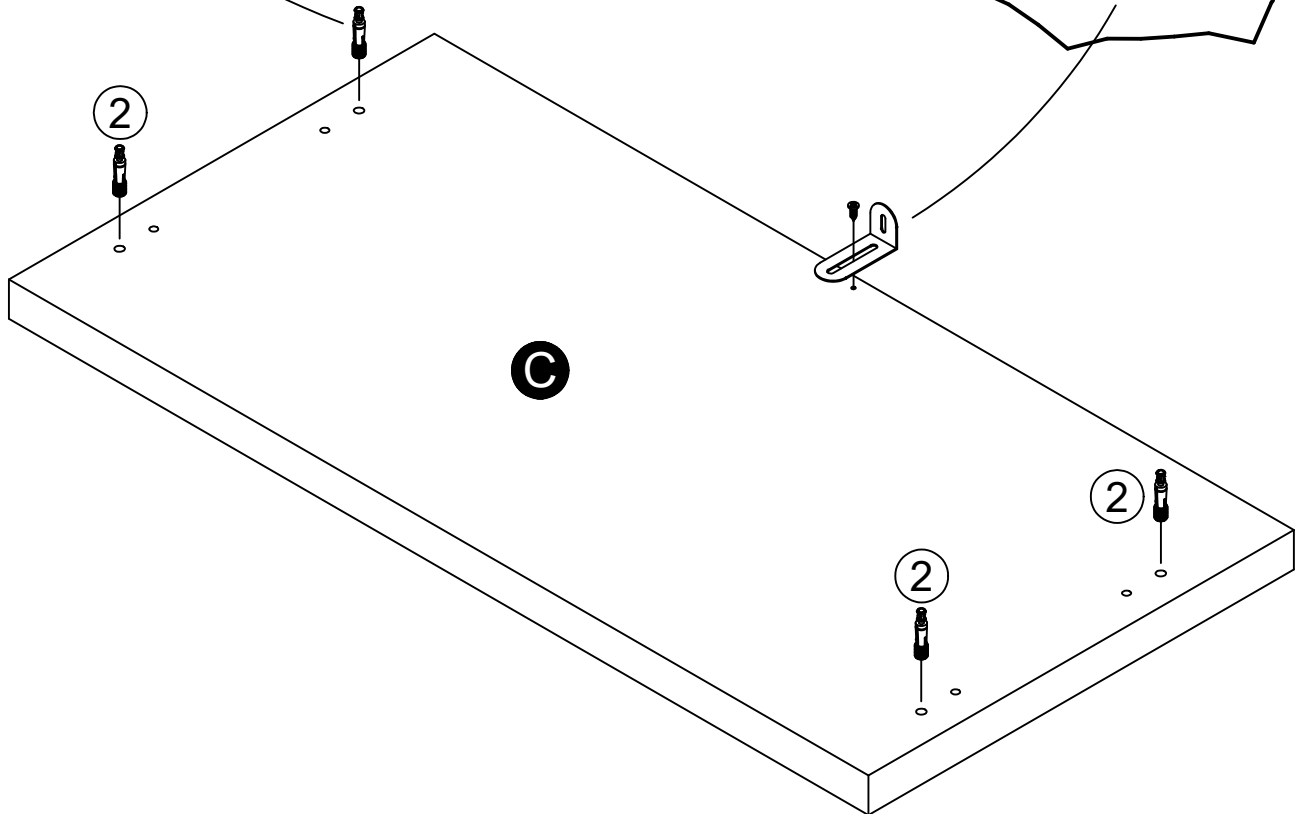
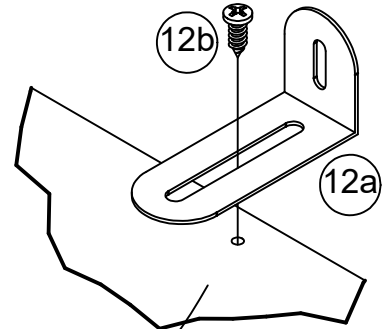

STEP 15

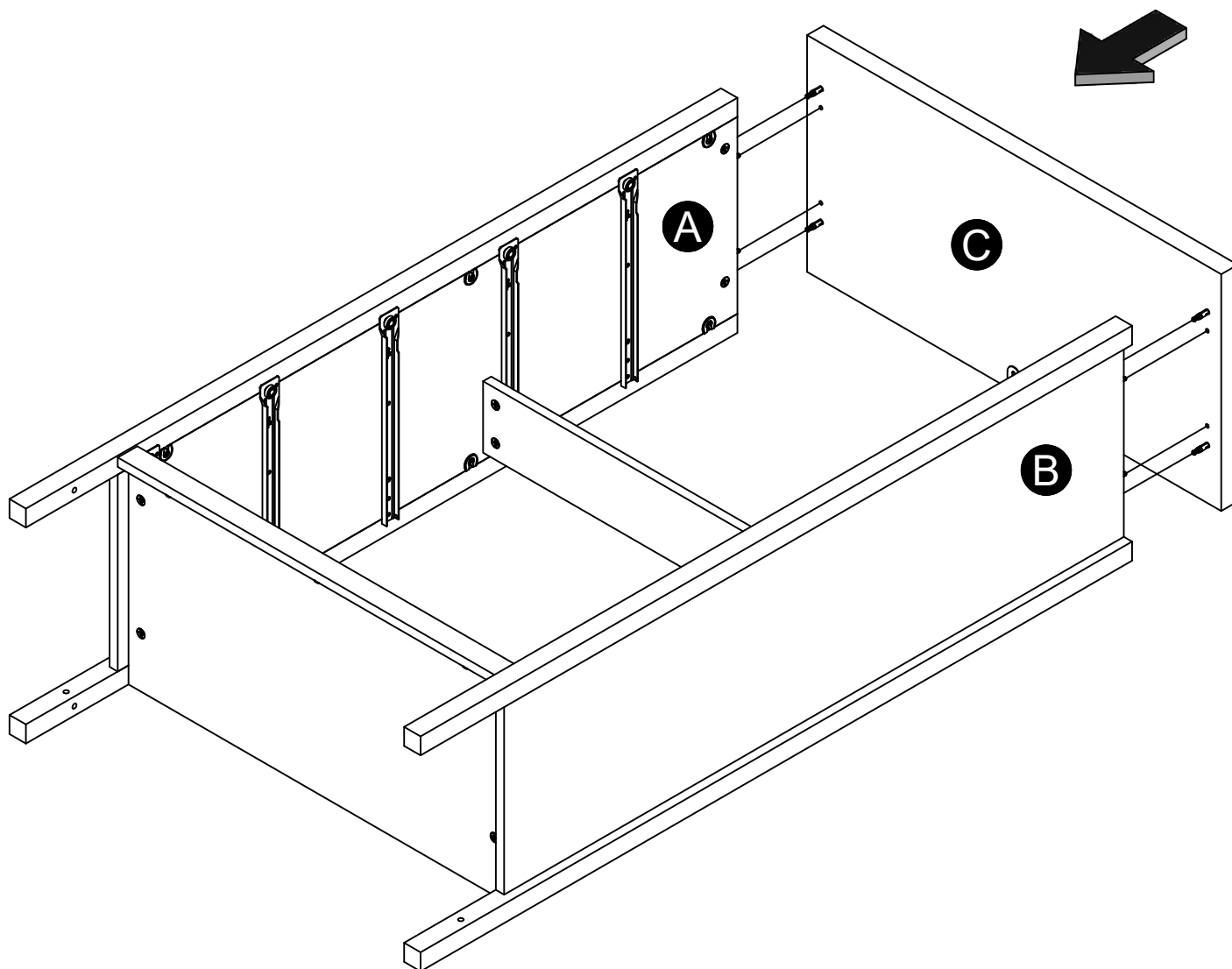
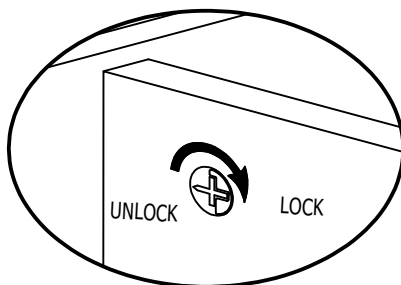
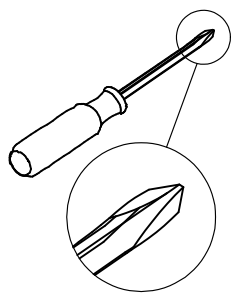

STEP 16

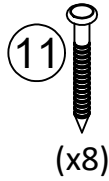
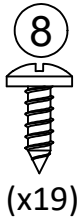
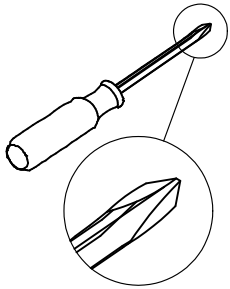

IMPORTANT! THE BACK PANEL IS A STRUCTURAL PART OF THIS UNIT AND MUST BE INSTALLED PROPERLY.

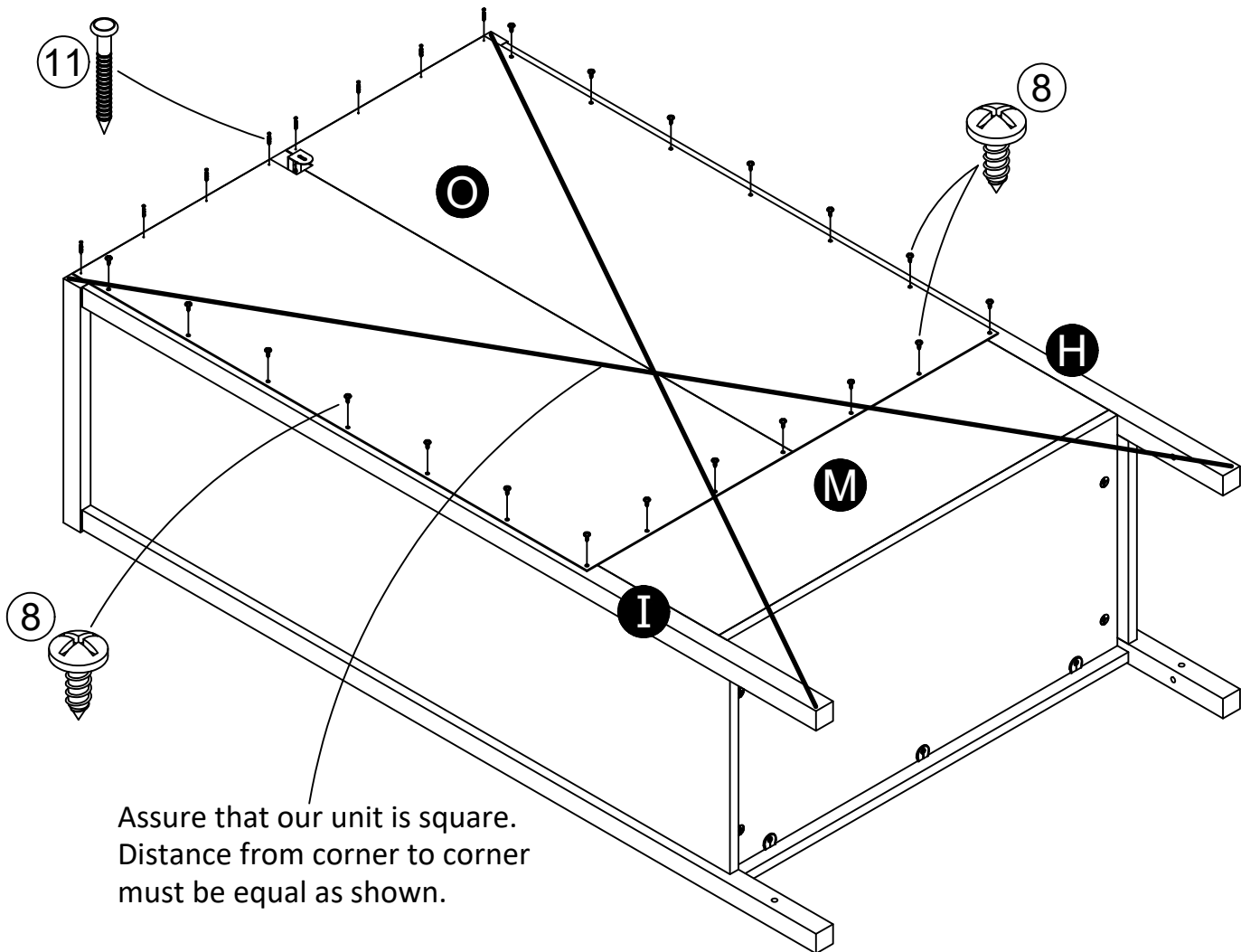

STEP 17

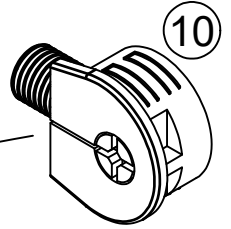
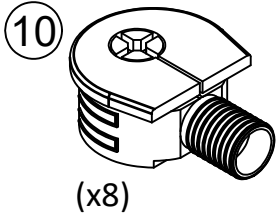

With the help of another person, flip unit on it's top.

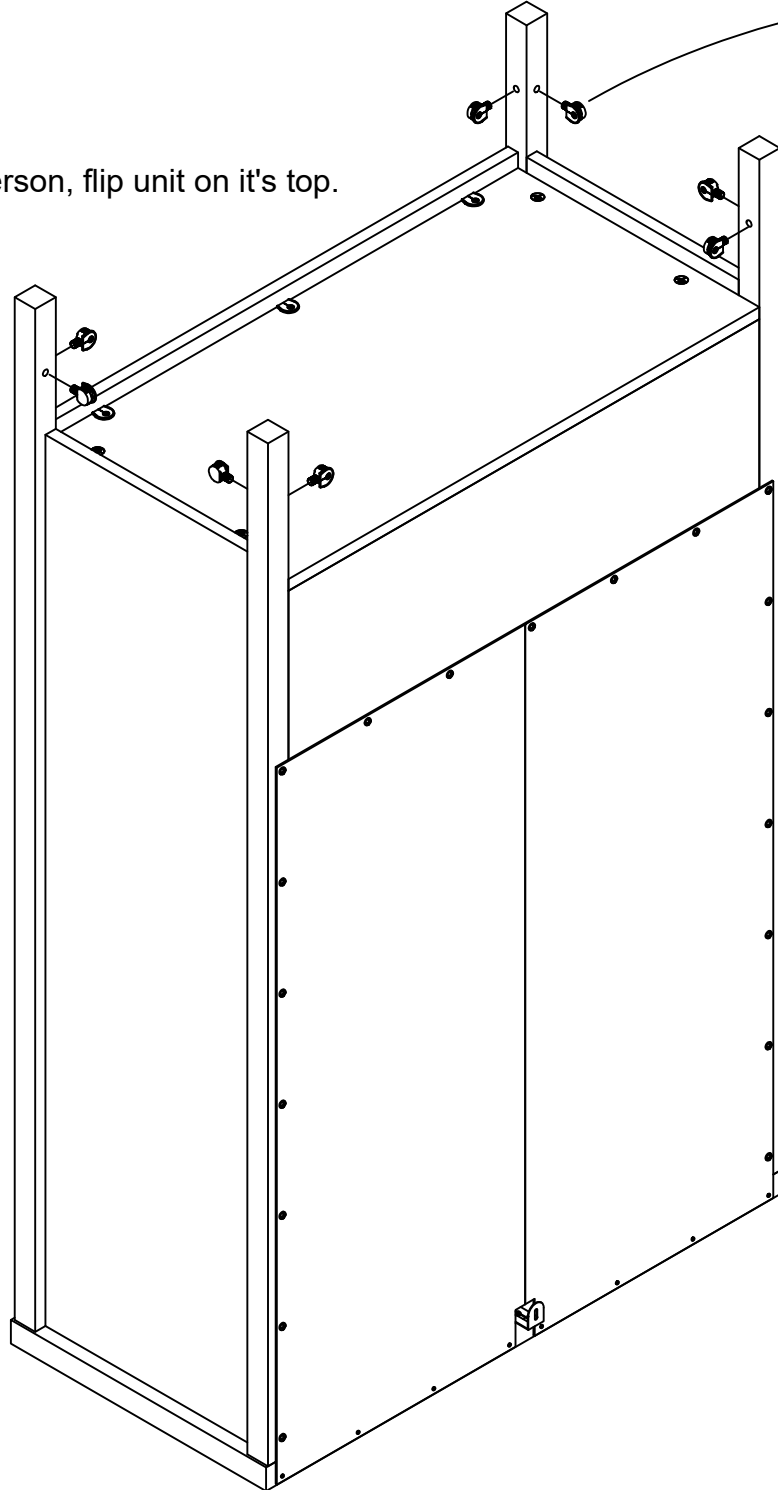
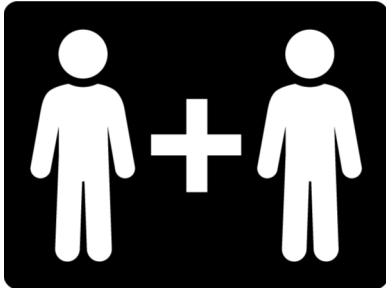

STEP 18

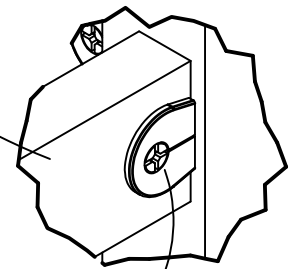
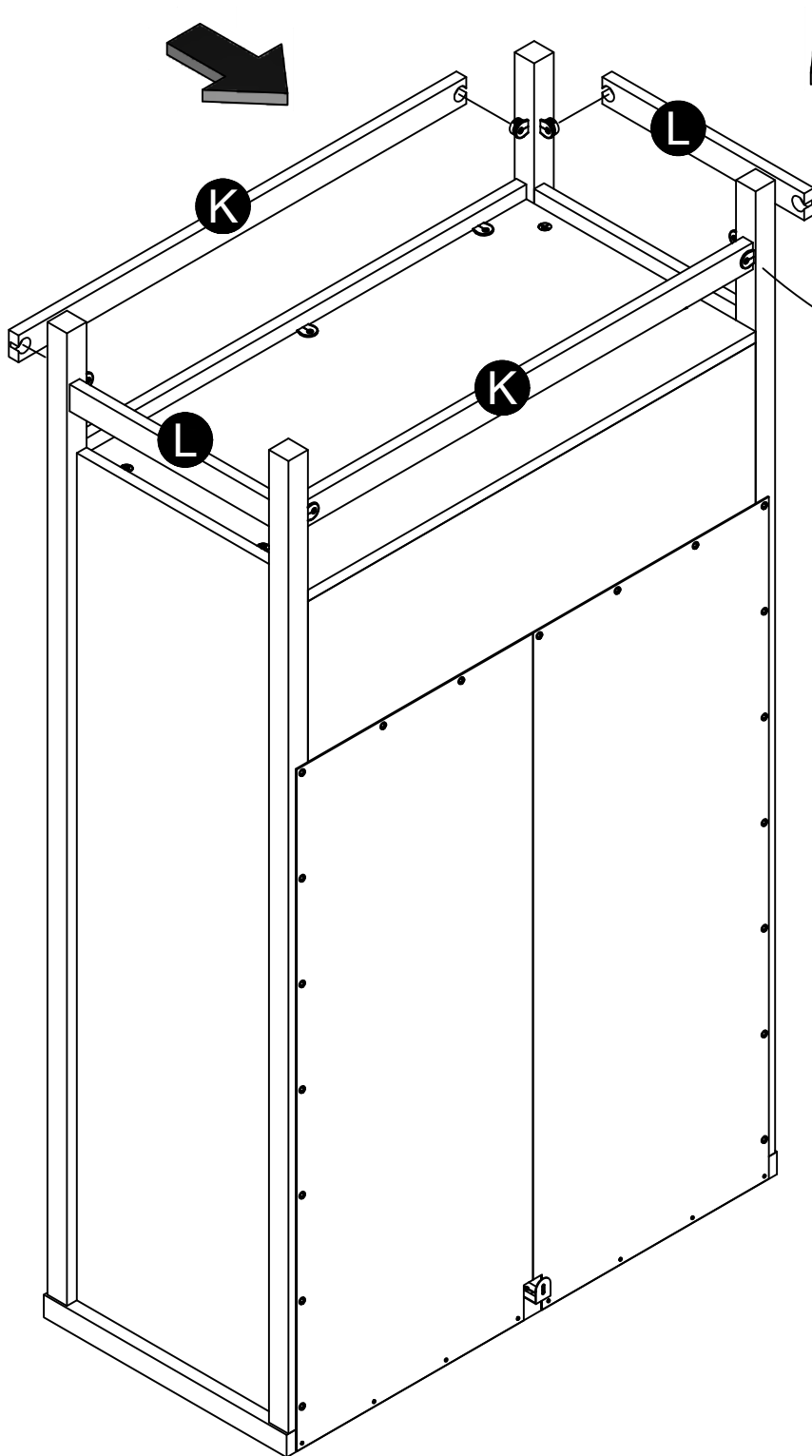
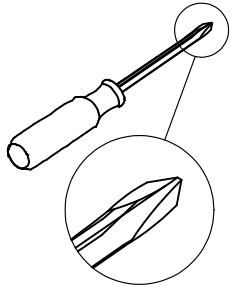

Lock parts together by turning screw in quickloc clockwise.

STEP 19

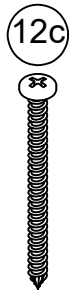
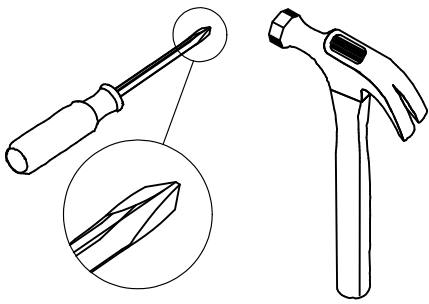

(x1)

For Masonry, Concrete, or other wall materials:

Consult your local hardware store for appropriate anchors to securely attach the safety bracket.

IMPORTANT: THIS UNIT MUST BE SECURE TO THE WALL TO HELP PREVENT TIPOVER. FOLLOW THESE INSTRUCTIONS TO INSTALL THE ANTI-TIPPING SAFETY BRACKET PROVIDED WITH THIS PRODUCT.

WARNING

Serious or fatal crushing injuries can occur from furniture tipover.

To prevent tipover:

- * Install tipover restraint provided
- * Place heaviest items in the lowest drawers
- * Unless specifically designed to accommodate, do not set TVs or other heavy objects on the top of this product
- * Never allow children to climb or hang on drawers, door, or shelves
- * Never open more than one drawer at a time

Use of tipover restraints may only reduce, but not eliminate the risk of tipover

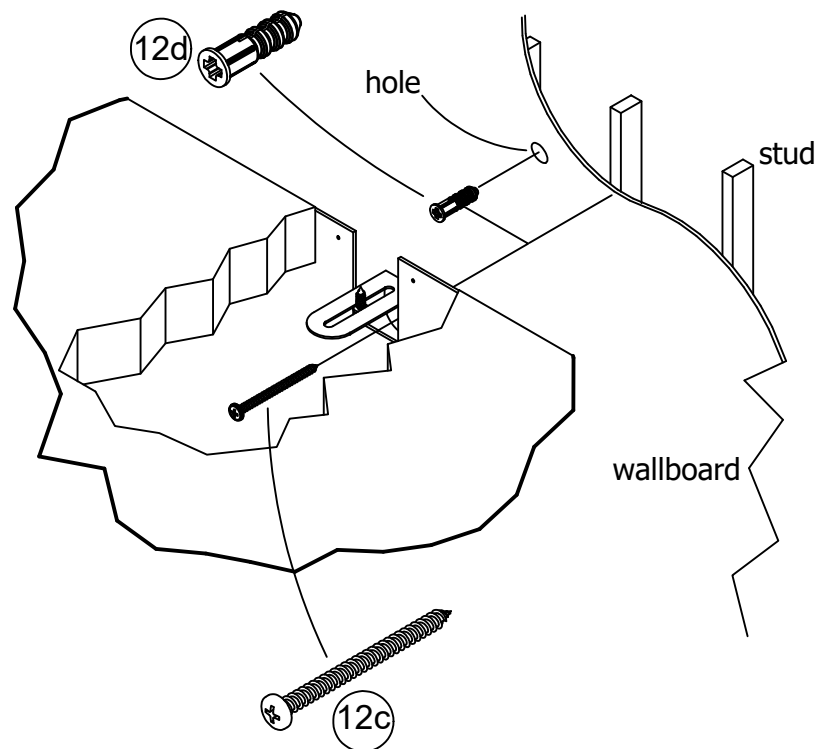

OPTION 1: Attachment into a wall stud (preferred method)

Using a stud finder, locate a stud in the wall. Place your unit against the wall, with the safety bracket aligned in this location. To make driving the screw easier, you can drill a 1/8" diameter pilot hole (3mm) through the safety bracket into the stud. Drive the screw through the safety bracket into the wall stud. Tighten the screw that was not fully tightened in step 14.

OPTION 2: Attachment into drywall

Locate your unit where desired against a wall and mark the wall through the safety bracket, then move your unit aside. Drill a 3/16" diameter hole (5mm) into the wallboard. Tap the wall anchor into the hole until it is flush. Move your unit into location and fasten the wall bracket to the wall anchor with the screw. Tighten the screw that was not fully tightened in step 14.

STEP 20

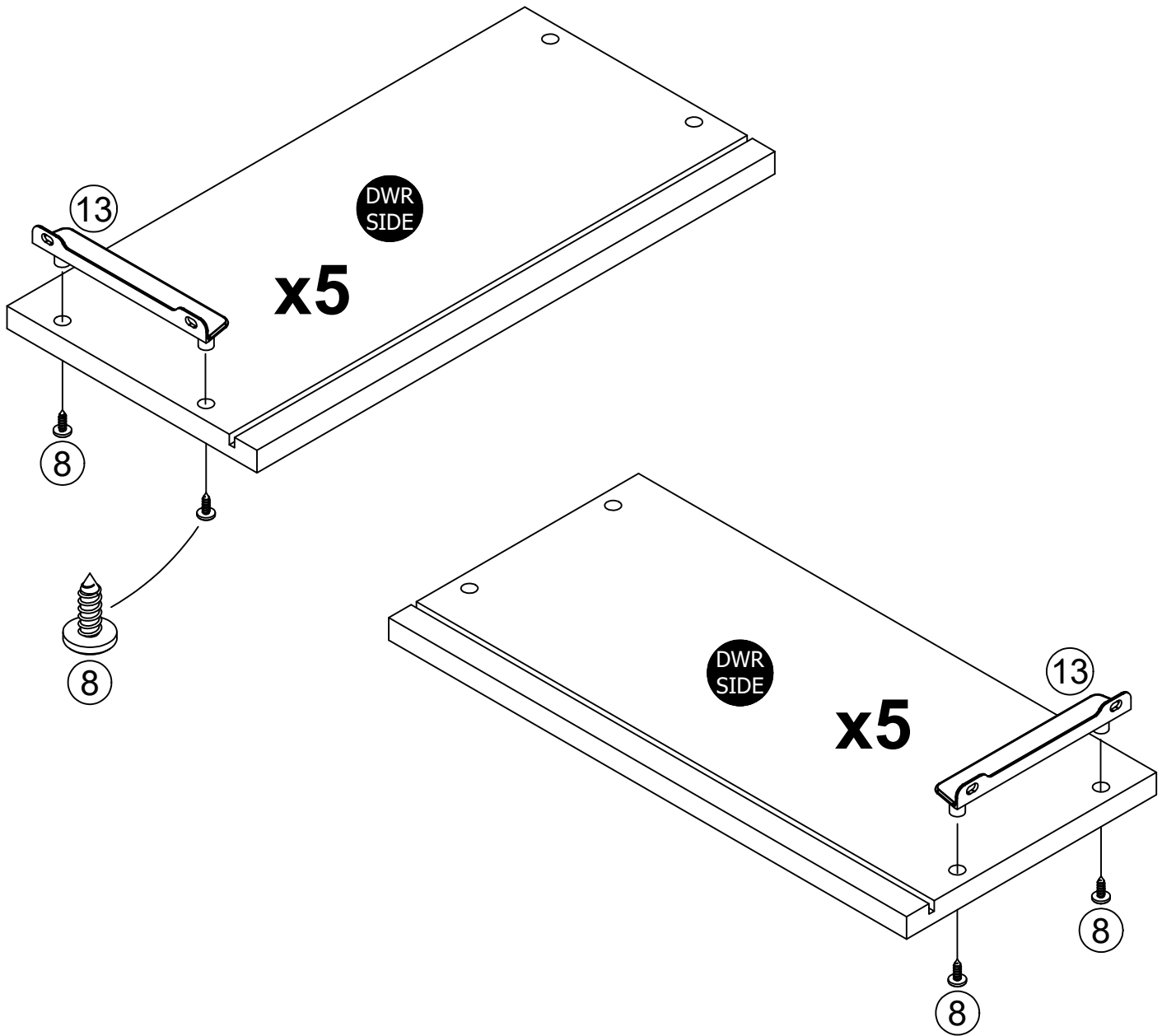
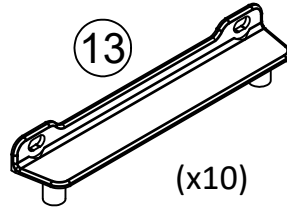
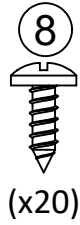
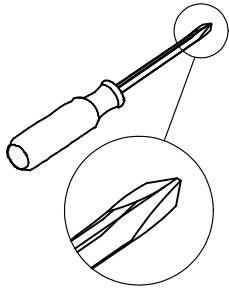

STEP 21

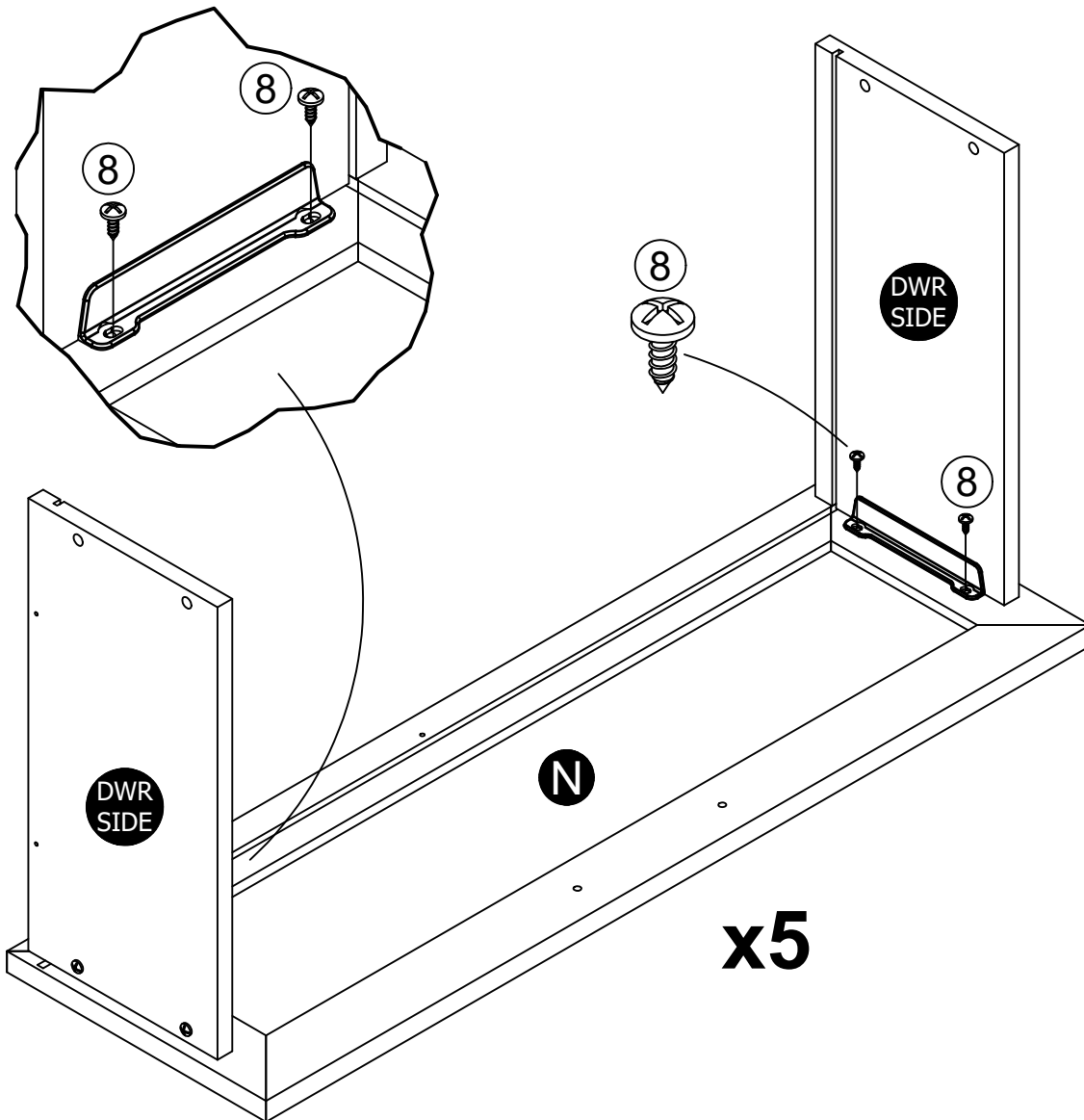
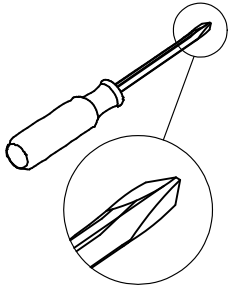

STEP 22

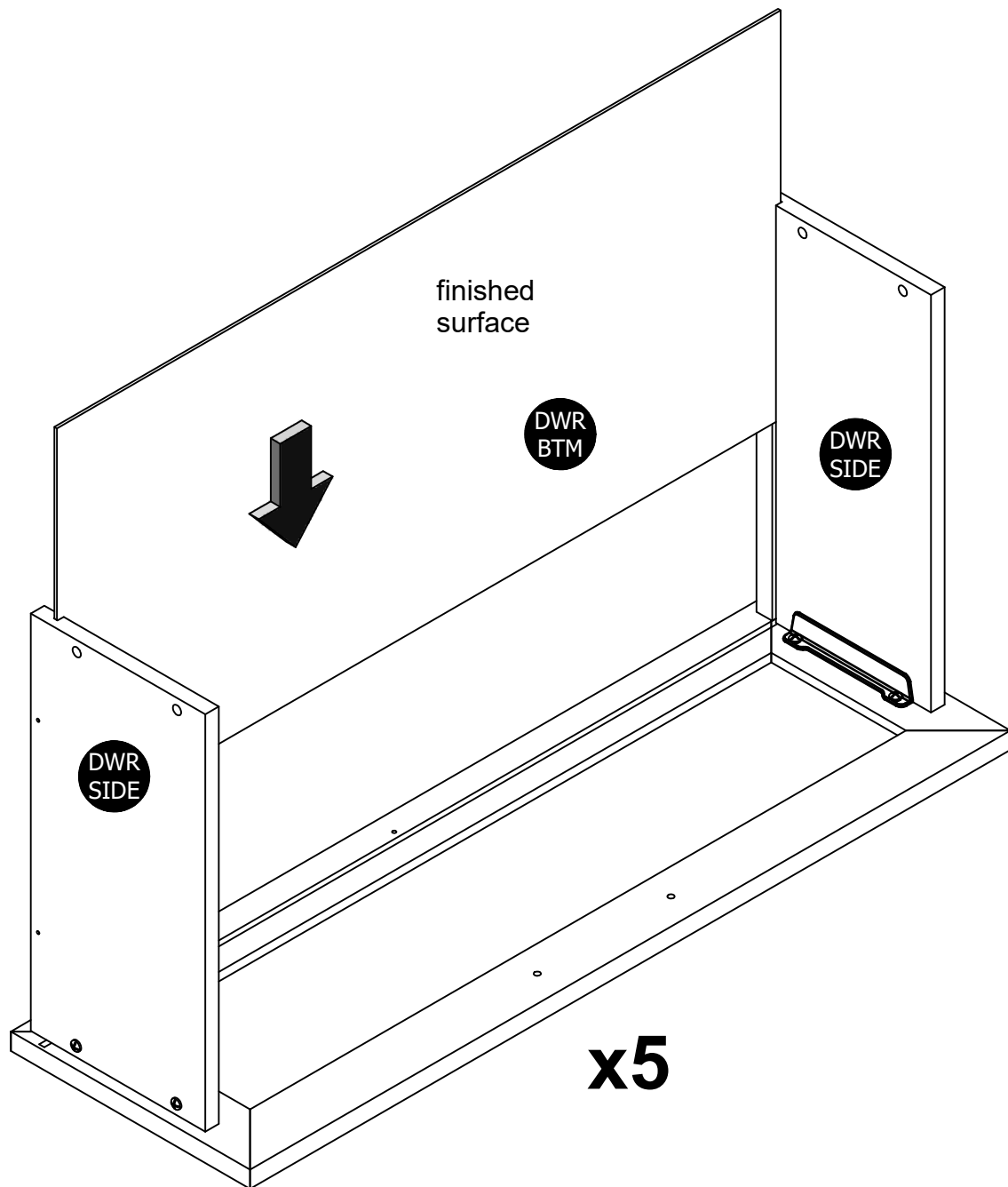

STEP 23

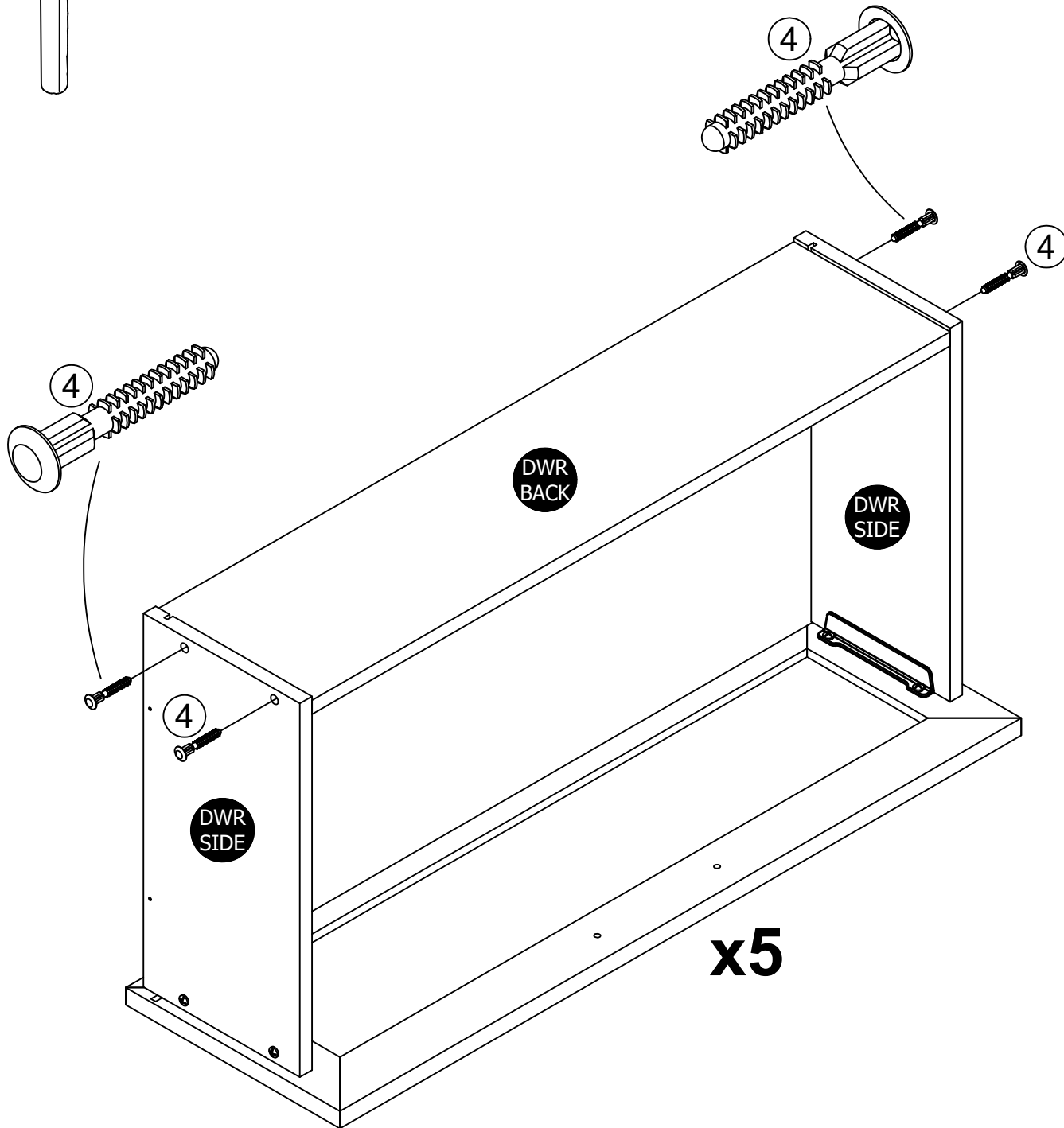
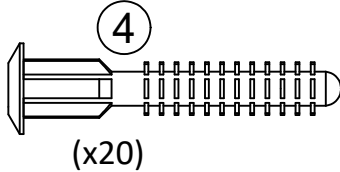

STEP 24

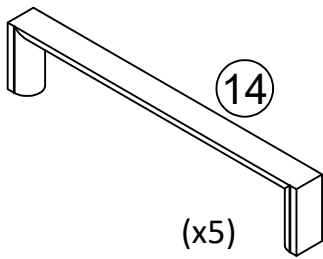
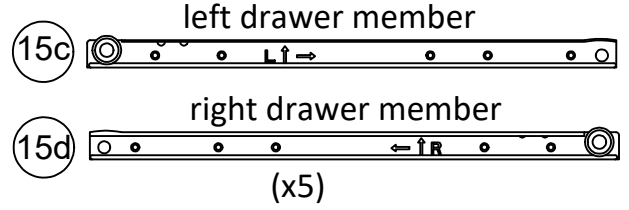
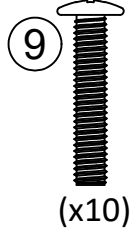
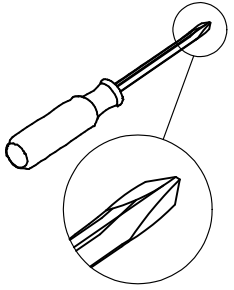

Attach slides first and then the handle.

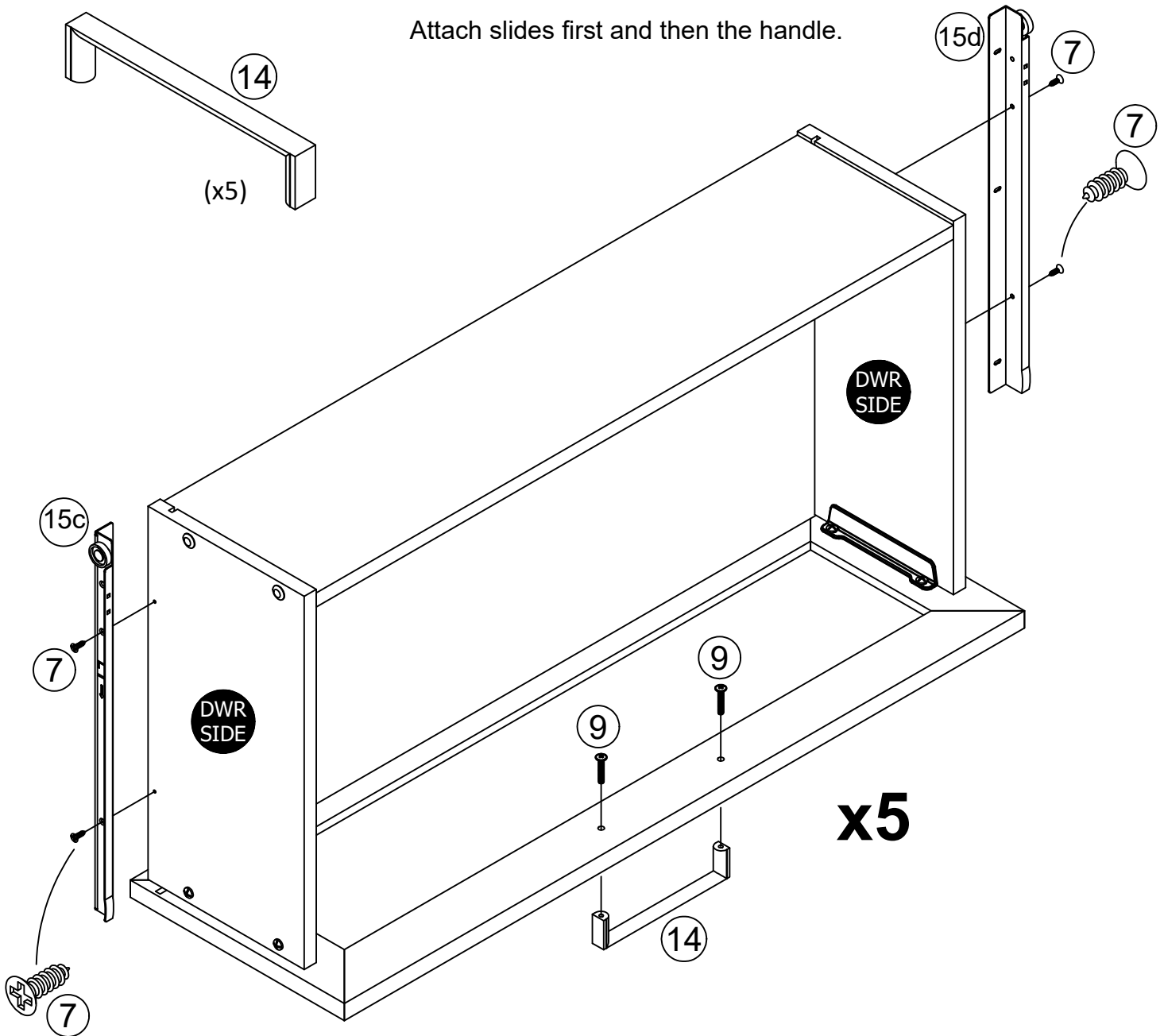

STEP 25

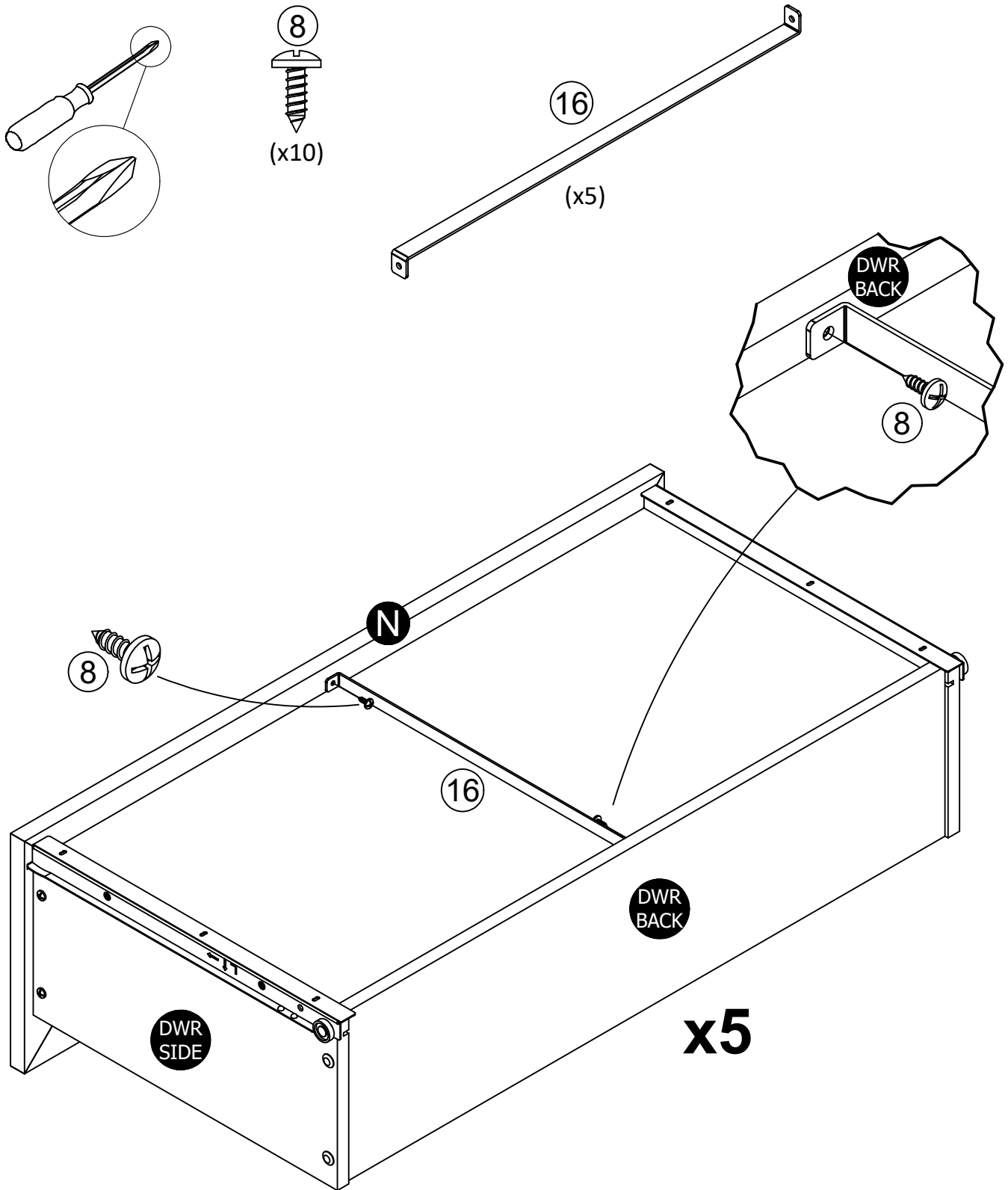

STEP 26

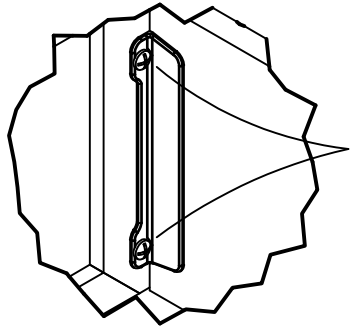

Note: The drawer bracket holes are slotted. Drawer fronts can be adjusted by loosening screws, making needed adjustments and retightening screws.

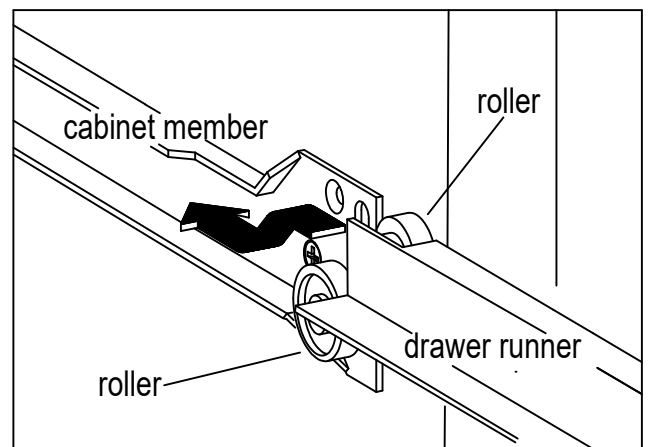
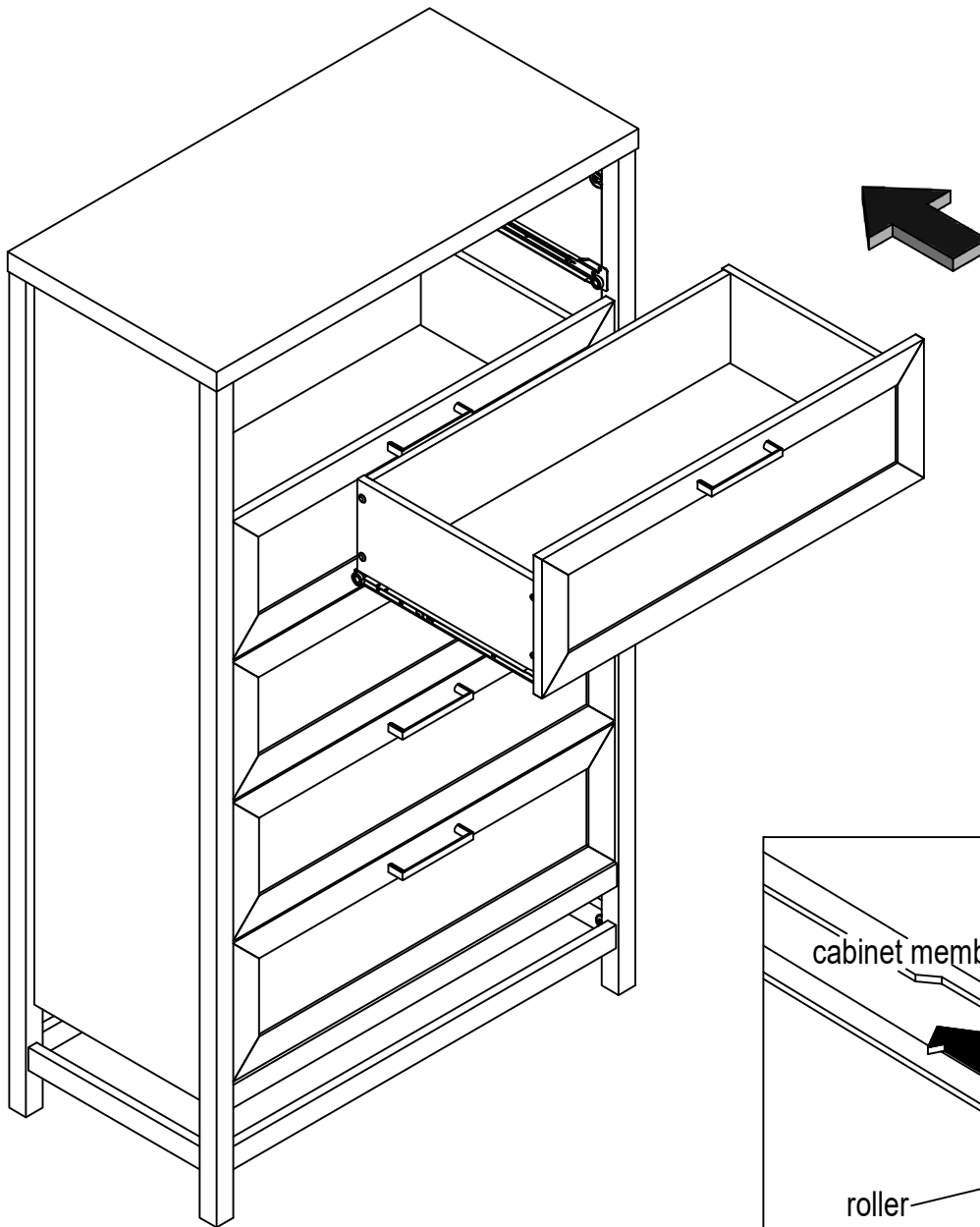

Maximum Loads

This unit has been designed to support the maximum loads shown. Exceeding these load limits could cause sagging, instability, product collapse, and/or serious injury.

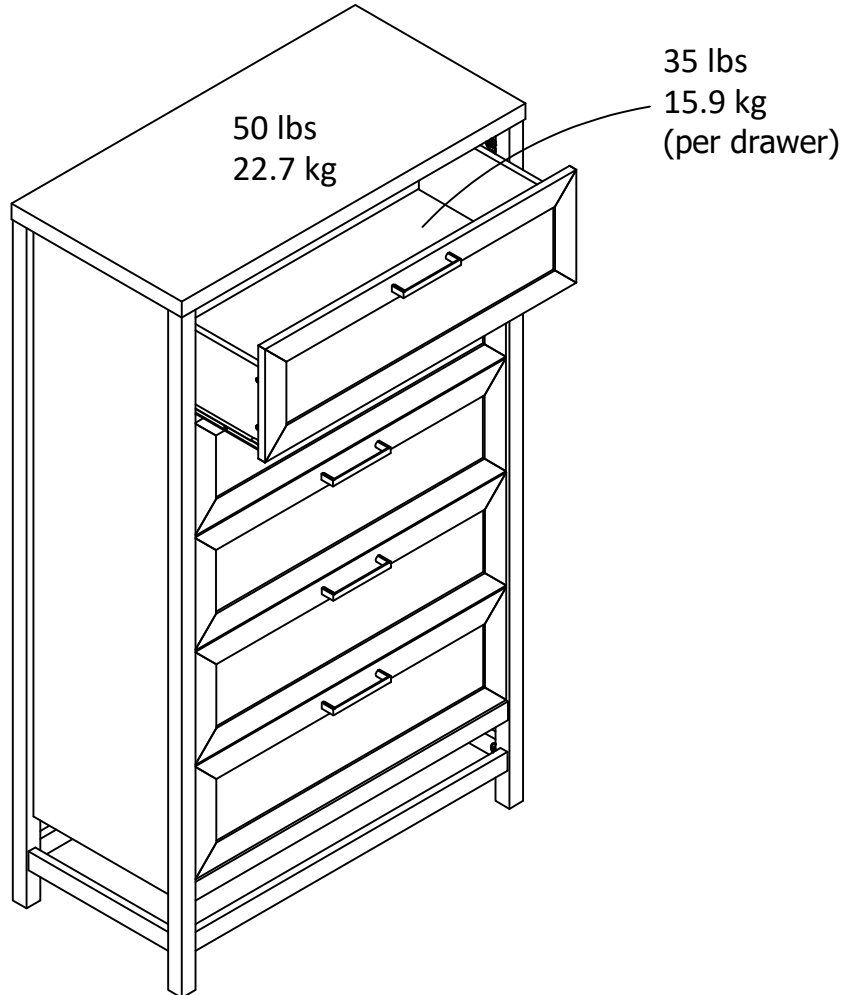

Warning: Risk of injury to persons - do not place a television on this furniture. This furniture is not approved for use with a television.

Certificate of Conformity

1. This certificate applies to the Dorel Home Furnishings, Inc. product identified by this instruction manual.
2. This certificate applies to compliance of this product with the CPSC Ban on Lead-Containing Paint (16 CFR 1303).
3. This product is distributed by: Dorel Home Furnishings, Inc.
410 East First Street South
Wright City, MO 63390
636-745-3351
4. Site of Manufacture: Tiffin OH
5. See front page of instruction manual for date of manufacture.

Register your product to receive the following:



- * New trend details - sneak peek on what's new
- * Surveys - have a voice within our community
- * Exclusive deals and discount codes
- * Quick and easy replacement part service

To register your product, visit ameriwoodhome.com

5 Star Rating



Visit your local retailer's website, rate your purchased product and leave us some feedback!

We would like to extend a big "Thank You" to all of our customers for taking the time to assemble this Ameriwood Home product, and to give us your valuable feedback.

*Thank
You!*

Cubierta Delantera

Este libro de instrucciones contiene información **IMPORTANTE** de seguridad. Por favor lea y manténgalo para referencia en el futuro.

No Regrese este producto! Comuníquese con nuestro amistoso equipo de servicio al cliente para obtener ayuda.

Llámenos al: 1-800-489-3351 (Gratis) Lunes - Viernes 9am - 5pm CST

Visitar: www.ameriwoodhome.com

PRECAUCION

Este mueble puede volcarse y causar graves heridas y/o muerte.

Anclar el mueble a un poste de madera en la pared (si esto se requiere).

No Permita que los niños monten el mueble.

Mantenga los artículos más pesados en los cajones de abajo.

Consejos Útiles (página 2)

- Abra su artículo en el área donde usted planea utilizarlo para evitar levantar y moverlo menos
- Identificar, ordenar y contar las piezas antes de intentar ensamblar
- Las clavijas de compresión se golpean con un martillo
- Las diapositivas están marcadas con una R (derecha) y L (izquierda) para la colocación correcta
- Asegúrese de que siempre este el punto localizado en la parte superior de bloqueador de leva este volteado hacia borde exterior
- Utilizar todos los clavos para el panel de atrás y distribuirlos por igual
- El panel de atrás debe utilizarse para asegurarse de que la unidad quede fija y firme
- No use químicas fuertes ni limpiadores abrasivos en este artículo
- Nunca empuje, tire ni arrastre los muebles

Antes de Que Empieces (página 3)

- Lea cuidadosamente cada paso y siga el orden correcto
- Separar y contar todas sus piezas y hardware
- Dése suficiente espacio para el proceso de ensamble
- Tenga las siguientes herramientas: destornillador de cabeza plana, #2 cabeza Phillips
Destornillador y martillo
- Precaución: Si usa un taladro electrónico o un destornillador eléctrico para atornillar, por favor asegúrese que deje de atornillar cuando el tornillo este apretado. Fallar hacer esto puede causar barrer el tornillo.

Sistema de fijar el bloqueo de leva (página 3)

Esta sistema de fijar el bloqueo de leva sera usado en todo el proceso ensamble.

Página 10/13

Necesitará golpear el conector (6) con un martillo para insertarlo completamente. Asegúrese de que el conector esté en la posición que se muestra antes de martillar para meterlo en el agujero.

Página 12/15

Ajuste el tornillo en sentido horario para que las partes queden fijas.

Página 18

Alinee los agujeros del riel del estante (E) con los cierres rápidos (10) y presione hacia abajo. Fije las partes girando el tornillo del cierre rápido en sentido horario.

Página 22

No ajuste el tornillo completamente.

Página 24

¡IMPORTANTE! EL PANEL POSTERIOR ES UN COMPONENTE ESTRUCTURAL DE ESTA UNIDAD Y DEBE SER INSTALADO ADECUADAMENTE.

Asegúrese de que nuestra unidad esté derecha. La distancia de esquina a esquina debe ser la misma, como se muestra.

Página 25

Con la ayuda de otra persona, voltee la unidad de modo que quede apoyada en su parte superior.

Página 26

Fije las partes girando el tornillo del cierre rápido en sentido horario.

Página 27

Para mampostería, hormigón u otros materiales de pared:

Consulte en su ferretería local por anclajes adecuados para acoplar el soporte de seguridad de manera segura.

IMPORTANTE: ESTA UNIDAD DEBE ESTAR FIJADA A LA PARED PARA AYUDAR A PREVENIR CAÍDAS. SIGA ESTAS INSTRUCCIONES PARA INSTALAR EL SOPORTE DE SEGURIDAD ANTICAÍDA INCLUIDO CON ESTE PRODUCTO.

ADVERTENCIA

Pueden ocurrir lesiones graves y hasta fatales debido a la caída de muebles.

Para prevenir caídas:

- *Instale el protector anticaída incluido
- *Coloque los objetos más pesados en los cajones de abajo
- *A menos que estén especialmente diseñados para este fin, no instale televisores u otros objetos pesados en la parte superior de este producto
- *Nunca permita que los niños trepen o se cuelguen de los cajones, la puerta o los estantes
- *Nunca abra más de un cajón a la vez

El uso de protectores anticaída puede reducir el riesgo de vuelco, pero no lo elimina

OPCIÓN 1: Fijar a un montante (método aconsejado)

Usando un detector de vigas, encuentre un montante en la pared. Coloque la unidad contra la pared, con el soporte de seguridad alineado en esta ubicación. Para que sea más fácil pasar el tornillo, puede perforar un agujero piloto de 1/8" de diámetro (3 mm) que traspase el soporte de seguridad y el montante. Pase el tornillo por el soporte de seguridad y el montante. Ajuste el tornillo que no quedó completamente ajustado en el paso 14.

OPCIÓN 2: Fijar a un muro seco

Ubique la unidad donde lo desee contra una pared y marque la pared usando el soporte de seguridad. Luego, corra la unidad a un lado. Perfore un agujero de 3/16" de diámetro (5 mm) en el muro seco. Martille el anclaje para pared en el agujero hasta que quede nivelado. Ponga la unidad en posición y ajuste el soporte de pared al anclaje de pared con el tornillo. Ajuste el tornillo que no quedó completamente ajustado en el paso 14.

Página 32

Acople las guías primero y luego el tirador.

Página 34

Nota: Los agujeros del soporte del cajón tienen ranuras. Se puede ajustar el frente de los cajones aflojando los tornillos, realizando los ajustes necesarios y volviendo a ajustar los tornillos.

Página 35

CARGA MAXIMA

Esta unidad ha sido diseñada para soportar la carga máxima anotada. El exceder estos límites puede causar inestabilidad, colapsarse y/o causar serias lesiones.

ADVERTENCIA: Riesgo de lesiones a las personas - no coloque un televisor sobre muebles. Este mueble no está aprobado para su uso con un televisor.

Página 36

Registre su producto para recibir lo siguiente:

- * Detalles de nuevas tendencias - Vistazo a lo nuevo
- * Encuestas - alee su voz entre su comunidad
- * Códigos de ofertas y descuentos exclusivos
- * Fácil y rápido servicio de partes de remplace

Para registrar su producto, visite ameriwoodhome.com

Clasificación de 5 estrellas

Visite el sitio web de su tienda local, califique su comprado y denos sus comentarios!

Nos gustaría enviar un gran "Agradecimiento" a todos nuestros clientes por tomarse el tiempo de ensamblar este producto de Ameriwood Home, y por darnos sus valiosos comentarios.

Gracias

Couverture Avant

CE LIVRET D'INSTRUCTION CONTIENT DES INFORMATIONS **IMPORTANTES** SUR LA SÉCURITÉ. VEUILLEZ LIRE ET GARDER POUR UNE RÉFÉRENCE FUTURE

Ne retournez pas ce produit! Contactez notre équipe de service à la clientèle amicale d'abord pour obtenir de l'aide.

Appelez-nous: 1-800-489-3351 (sans frais) du Lundi au Vendredi de 9h à 17h Heure Centrale

Visitez: www.ameriwoodhome.com

ATTENTION

Le meuble peut basculer et causer des blessures graves ou la mort.

Ancrer le meuble à une planche murale dans le mur (si indiqué).

Ne laissez pas les enfants grimper sur le meuble.

Placez les articles lourds sur les étagères ou dans les tiroirs inférieurs.

Astuces Utiles (page 2)

-Ouvrez votre article dans la zone que vous prévoyez de le garder pour moins de levage lourd

-Identifier, trier et compter les pièces avant d'essayer d'assembler

-Les goujons de compression sont taraudés avec un Marteau

-Les glissières sont marquées d'un R (droit) et d'un L (gauche) pour un bon placement

-Assurez-vous toujours de faire face la pointe situé sur le haut de la Serrure de Came vers le bord extérieur

-Utiliser tous les clous fournis pour le panneau arrière et les répartir également

-Le panneau arrière doit être utilisé pour vous assurer que votre appareil est robuste

-N'utilisez pas de produits chimiques agressifs ou de nettoyeurs abrasifs sur cet appareil

-Ne jamais pousser, tirer, ou faire glisser votre meuble

Avant de Commencer (page 3)

-Lisez attentivement chaque étape et suivez le bon ordre

-Séparez et comptez toutes vos pièces et matériaux

-Donnez-vous suffisamment de place pour l'assemblage

-Avoir les outils suivants: tournevis à tête plate, #2 tournevis Phillips, et Marteau

-Attention: Si vous utilisez une perceuse électrique ou un tournevis électrique pour visser, veillez à ralentir et arrêter lorsque la vis est bien serrée. Le non-respect de cette consigne peut endommager la vis.

Système de Fixation de Came (page 3)

Ce Système de Fixation de Came sera utilisé tout au long de l'assemblage

Page 10 / 13

Vous devrez taper sur le raccord (6) avec un marteau pour l'insérer complètement. Assurez-vous que le raccord est positionné comme indiqué avant de le taper dans le trou.

Page 12 / 15

Tournez la vis dans le sens des aiguilles d'une montre pour verrouiller les pièces en place.

Page 18

Alignez les trous du rail de l'étagère (E) avec les verrous rapides (10) et appuyez dessus. Verrouillez les pièces ensemble en tournant la vis du verrou dans le sens des aiguilles d'une montre.

Page 22

Ne serrez pas complètement la vis.

Page 24

IMPORTANT ! LE PANNEAU ARRIÈRE EST UNE PARTIE STRUCTURELLE DE CETTE UNITÉ ET DOIT ÊTRE INSTALLÉ CORRECTEMENT.

Assurez-vous que l'unité est d'équerre. La distance d'un coin à l'autre doit être égale, comme indiqué.

Page 25

Avec l'aide d'une autre personne, retournez l'unité sur le dessus.

Page 26

Verrouillez les pièces ensemble en tournant la vis du verrou rapide dans le sens des aiguilles d'une montre.

Page 27

Pour la maçonnerie, le béton ou d'autres matériaux muraux :

Consultez votre quincaillerie locale pour obtenir les ancrages appropriés afin de fixer solidement le support de sécurité.

IMPORTANT : CET APPAREIL DOIT ÊTRE FIXÉ AU MUR POUR ÉVITER TOUT BASCULEMENT. SUIVEZ CES INSTRUCTIONS POUR INSTALLER LE SUPPORT DE SÉCURITÉ ANTI-BASCULEMENT FOURNI AVEC CE PRODUIT.

AVERTISSEMENT

Le basculement d'un meuble peut entraîner des blessures graves ou mortelles dues à l'écrasement.

Pour éviter le basculement :

- * Installez le dispositif de blocage du basculement prévu
- * Placez les articles les plus lourds dans les tiroirs les plus bas.
- * Ne posez pas de téléviseurs ou d'autres objets lourds sur le dessus de ce produit, sauf s'ils ont été spécifiquement conçus à cet effet.
- * Ne permettez jamais aux enfants de grimper ou de s'accrocher aux tiroirs, aux portes ou aux étagères.
- * N'ouvrez jamais plus d'un tiroir à la fois.

L'utilisation de dispositifs de blocage en cas de basculement peut seulement réduire, mais pas éliminer, le risque de basculement.

OPTION 1 : Fixation dans un montant de mur (méthode préférée)

À l'aide d'un guide de montage, localisez un montant dans le mur. Placez votre unité contre le mur, avec le support de sécurité aligné à cet endroit. Pour faciliter l'insertion de la vis, vous pouvez percer un trou pilote de 3 mm de diamètre à travers le support de sécurité dans le montant. Enfoncez la vis à travers le support de sécurité dans le montant du mur. Serrez la vis qui n'a pas été entièrement serrée à l'étape 14.

OPTION 2 : Fixation dans une cloison sèche

Placez votre unité à l'endroit souhaité contre un mur et marquez le mur à travers le support de sécurité, puis mettez votre unité de côté. Percez un trou de 3/16" de diamètre (5mm) dans le panneau mural. Tapez sur l'ancrage mural dans le trou jusqu'à ce qu'il soit affleurant. Mettez votre appareil en place et fixez le support mural à l'ancrage mural à l'aide de la vis. Serrez la vis qui n'a pas été entièrement serrée à l'étape 14.

Page 32

Fixez d'abord les glissières, puis la poignée.

Page 34

Remarque : Les trous du support de tiroir sont fendus. Les façades des tiroirs peuvent être ajustées en desserrant les vis, en effectuant les ajustements nécessaires et en resserrant les vis.

Page 35

CHARGES MAXIMALES

Ce meuble a été conçu pour supporter les charges maximales indiquées. En excédant ces limites de charge, le meuble pourrait devenir instable, s'effondrer, et/ou causer des blessures graves.

AVERTISSEMENT : Risque de blessure corporelle - ne pas placer une télévision sur ce meuble. Ce meuble n'est pas approuvé pour une utilisation avec une télévision.

Page 36

Enregistrez votre produit pour recevoir les éléments suivantes:

- * Détails sur les nouvelles tendances - un aperçu sur les nouveautés
- * Sondages - avoir une voix au sein de notre communauté
- * Offres exclusives et codes promo
- * Service de pièces de rechange rapide et facile

Pour enregistrer votre produit, visitez ameriwoodhome.com

5 Étoiles

Visitez le site Web de votre détaillant local, évaluez votre produit acheté et laissez-nous quelques commentaires !

Nous tenons à offrir un grand "Merci" à tous nos clients pour avoir pris le temps d'assembler ce produit "Ameriwood Home", et de nous donner vos commentaires précieux.

Merci